

H TECHNICAL PUBLICATION

Bar Pin Alignment 340 Thru 520 Series

NO: 17730-213

SUBJECT: Bar Pin Alignment Instructions

DATE: November 1997 REVISION: C

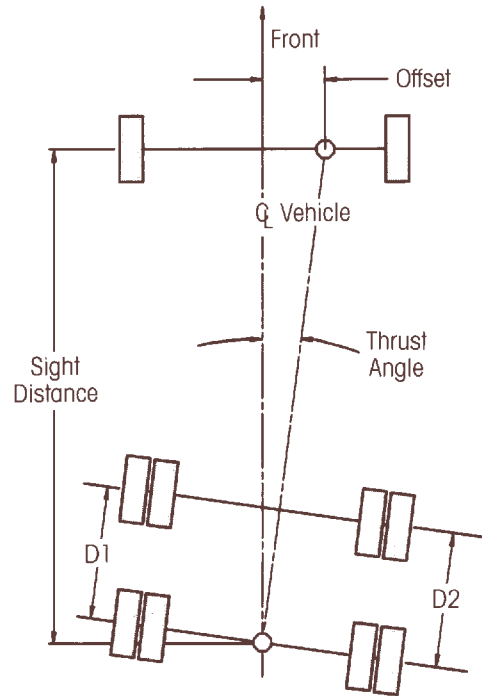
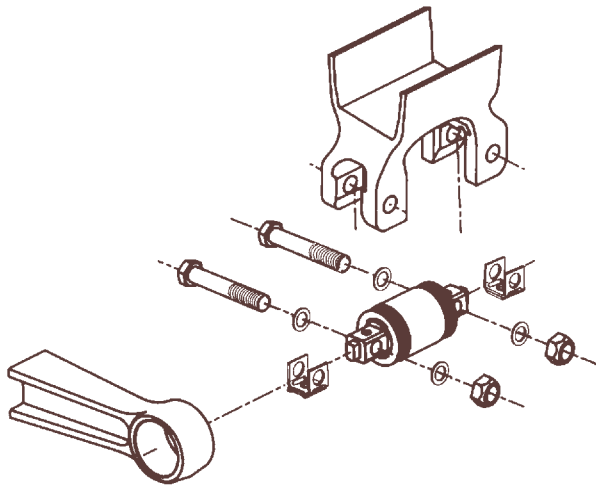
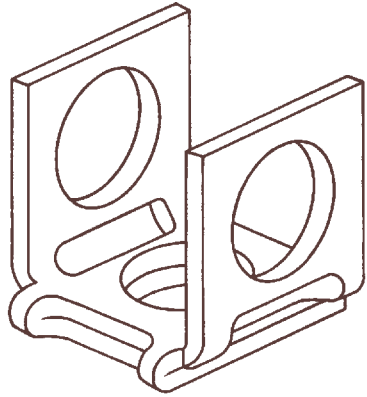

CONTENTS

Item	Subject	Page
1	Introduction	2
2	Bar Pin Beam End Connection Features	2
3	Important Safety Notice	2-3
4	Description	3-4
5	Alignment Rear Tandem Axle	4-13
6	Adjustment Front Tandem Axle	13-20

For The Road Ahead

H HENDRICKSON



Subject 1

INTRODUCTION

This publication is intended to acquaint and assist maintenance personnel in the proper use of the Hendrickson adjustable bar pin beam end connection.

Use only genuine Hendrickson replacement pads for aligning equalizer beam suspensions. Most Hendrickson parts can be identified by the Hendrickson  trademark.

Note the date of this publication. Hendrickson Suspension periodically revises and updates this publication. If this copy is more than one year old, contact Hendrickson Suspension to determine if a later copy is available.

Subject 2

BAR PIN BEAM END CONNECTION FEATURES

Application:

Some vehicles will come equipped with the adjustable bar pin beam end connection; others may require change over from the non-adjustable bar pin beam end connection. In the latter case, replace the non-adjustable bar pin bushing, P/N 50150-000, with the adjustable bushing, P/N 50160-000. The non-adjustable bushing has full width axle connection lugs without adjustment shims. The adjustable bushing has narrower axle connection lugs and must be used with adjustment shims. (See Technical Publication 17730-190 for proper rebush procedures.)

Adjustment Shims:

Three (3) genuine Hendrickson shims are available for tandem axle adjustment. The first shim, P/N 50130-000, is typically for OEM usage and will usually be encountered at the first vehicle alignment. Shims 50131-000 provide finer adjustment resolution. Shims 57026-000 are easier to remove and replace. **USE OF SUBSTITUTES FOR GENUINE HENDRICKSON SHIMS MAY RESULT IN A LOOSE OR BROKEN CONNECTION, WHICH COULD CAUSE LOSS OF VEHICLE CONTROL, POSSIBLY CAUSING PERSONAL INJURY OR PROPERTY DAMAGE.**

Limits of Adjustment:

Axle thrust angle misalignment conditions up to 1.2 degrees can be corrected depending upon initial shim placement and OEM recommendations. Tandem axle non-parallel conditions up to 2 inches can be corrected depending upon initial shim placement and OEM recommendations. The smallest rear tandem axle thrust

angle and non-parallel conditions which can be corrected are 0.10 degrees and 0.167 inches respectively. A change of 1/16" at one beam end connection of a tandem axle provides a 0.10 degree thrust angle correction and a 0.167" axle spacing correction measured at the axle shaft drill centers. A change of 1/16" at both beam ends of a tandem axle provides a 0.20 degree thrust angle correction and a 0.334" axle spacing correction when measured at the axle drill centers.

Bolts/Nuts/Washers:

The bolts, nuts and washers provided by Hendrickson with bushing P/N 50160-000 are designed for specific use with bar pin style axle attachments. When aligning/rebushing a vehicle, always use new genuine Hendrickson bolts, nuts and washers. **USE OF SUBSTITUTES FOR GENUINE HENDRICKSON SHIMS MAY RESULT IN A LOOSE OR BROKEN CONNECTION, WHICH COULD CAUSE LOSS OF VEHICLE CONTROL, POSSIBLY CAUSING PERSONAL INJURY OR PROPERTY DAMAGE.**

Subject 3

IMPORTANT SAFETY NOTICE

Proper service and repair is important to the safe and reliable operation of the tandem suspension. The service procedures recommended by Hendrickson and described in this technical publication are effective methods of performing maintenance. Some of these operations may require the use of shop made tools for removal and installation of bushings.

There are various warnings that should be read carefully to minimize the risk of personal injury and to assure that proper methods are used. Improper servicing may damage the vehicle or render it unsafe in operation.

WARNING:

HENDRICKSON SUSPENSION REMINDS USERS TO ADHERE TO THE PUBLISHED CAPACITY RATINGS FOR THE SUSPENSIONS. ADD-ON AXLE ATTACHMENTS AND OTHER LOAD TRANSFERRING DEVICES CAN INCREASE THE SUSPENSION LOAD ABOVE THE RATED AND APPROVED CAPACITIES WHICH COULD RESULT IN COMPONENT FAILURE AND LOSS OF VEHICLE CONTROL, POSSIBLY CAUSING PERSONAL INJURY OR PROPERTY DAMAGE.



DO NOT MODIFY OR REWORK PARTS. DO NOT USE SUBSTITUTE PARTS. USE OF A MODIFIED OR SUBSTITUTE PART IS NOT RECOMMENDED BECAUSE THE PART MAY NOT MEET HENDRICKSON'S SPECIFICATIONS. THIS COULD RESULT IN FAILURE OF THE PART, LOSS OF VEHICLE CONTROL, POSSIBLE PERSONAL INJURY OR PROPERTY DAMAGE.

DO NOT USE A CUTTING TORCH TO REMOVE ANY ATTACHING FASTENERS. DO NOT USE A CUTTING TORCH TO REMOVE THE EQUALIZING BEAMS FROM THE AXLES OR TO REMOVE THE BUSHINGS FROM THE BEAM CENTERS OR ENDS. THE USE OF HEAT ON SUSPENSION COMPONENTS WILL ADVERSELY AFFECT THE STRENGTH OF THESE PARTS. A COMPONENT DAMAGED IN THIS MANNER MAY RESULT IN PART FAILURE, THE LOSS OF VEHICLE CONTROL, POSSIBLE PERSONAL INJURY OR PROPERTY DAMAGE.

A MECHANIC USING A SERVICE PROCEDURE OR TOOL WHICH HAS NOT BEEN RECOMMENDED BY HENDRICKSON MUST FIRST SATISFY HIMSELF THAT NEITHER HIS SAFETY NOR THE VEHICLE'S SAFETY WILL BE JEOPARDIZED BY THE METHOD OR TOOL SELECTED.

Subject 4
DESCRIPTION

The adjustable bar pin beam end connection permits tandem axles with equalizer beam suspensions to be aligned relative to the vehicle centerline or steer axle and to each other. Maintaining proper wheel/axle alignment will prolong tire life, improve fuel economy, lessen maintenance on other suspension and drive line components.

Each adjustable bar pin beam end connection is

Figure 1—Bar Pin Beam End Connection with Shim

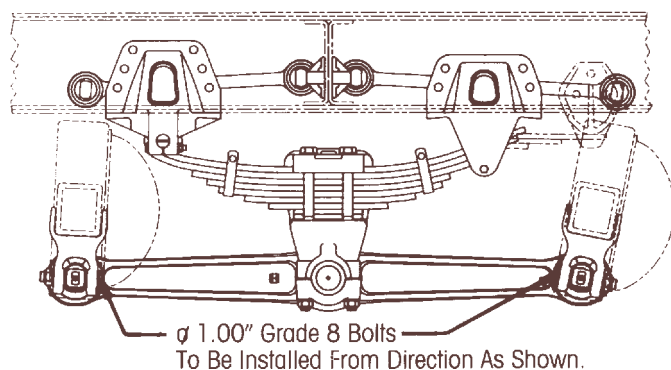

fastened to the axle by two (2) one inch diameter, Grade 8 (high strength) bolts and two (2) one inch, Grade C locknuts. One inch I.D. hardened, flat washers are located under both the bolt head and the locknut. The bolts are positioned parallel to the vehicle longitudinal axis making removal and assembly easy. Bolts are to be inserted from the centerline of the tandem axle to the outside as shown in Figure 1.

The adjustable bar pin beam end connection is a rubber bushing assembly consisting of a rubber insert sandwiched between an outer metal tube and an inner bar pin metal. The rubber insert is restricted at both ends by steel confinement washers. The alignment shims slip over the ends of the bar pin. See Figure 2.

The alignment feature consists of specially designed, tightly toleranced steel shims which fill the 3/8" total gap between the bushing inner metal and the axle bracket legs. The gap must be filled by placing the shims on the bushing assembly in one of the positions shown in Figure 3, 4 or 5. Hendrickson has provided three shim designs, P/N 50130-000, 50131-000 and 57026-000 for ease of alignment. Each shim has been designed to completely fill the gap, while providing the necessary adjustment. Figure 6 shows an isometric view of each genuine Hendrickson shim.

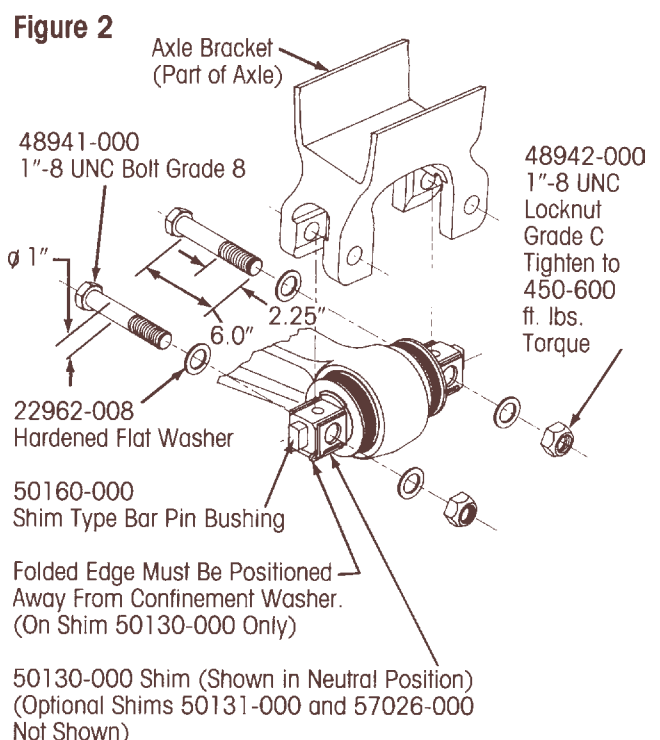



Subject 4 (Continued)

DESCRIPTION

Note the part numbers and material thickness stamped on each shim leg.

WARNING: A SHIM MUST BE INSTALLED AT EACH BOLT LOCATION. THE SAME PART NUMBER SHIM IN THE SAME ORIENTATION MUST BE USED AT BOTH BOLT LOCATIONS ON ANY ONE BUSHING ASSEMBLY. DO NOT INSTALL OR STACK MORE THAN ONE SHIM AT EACH BOLT LOCATION. USE GENUINE HENDRICKSON SHIMS, DO NOT USE STANDARD WASHERS. THE FAILURE TO FOLLOW THESE WARNINGS MAY RESULT IN THE FRACTURE OF EITHER THE BRACKET OR BAR PIN WHICH COULD RESULT IN THE LOSS OF VEHICLE CONTROL AND POSSIBLE PERSONAL INJURY OR PROPERTY DAMAGE.

Subject 5

ALIGNMENT REAR TANDEM AXLE

The following procedure is recommended when axle alignment is required for the rear tandem axle using the adjustable bar pin beam end connection. This procedure should be performed after all repairs are completed and all suspension fasteners have been tightened to specified torque values.

1. Place vehicle on level floor. Free and center all suspension joints by slowly moving vehicle back and forth several times without using the brakes.
2. Chock front wheels and make sure vehicle brakes are released.
3. Determine the thrust angle of the rear tandem axle relative to the vehicle centerline. When using computerized alignment equipment, the thrust angle is read directly from the computer screen or from a computer printout. When using laser projection alignment equipment, the light beam offset from the centerline of the front target must be measured. This measured offset must then be related to Table No. 1 or Table No. 2 to determine the actual thrust angle. Table Nos. 1 and 2 are used to convert measured offset to thrust angle. The sight distance in Table Nos. 1 and 2 is the distance from the front laser target near the front steer axle to the centerline of the rear tandem axle. For example, when using laser alignment equipment on a vehicle with a 287" sight distance, an offset measurement of 1.0" converts to a thrust angle of 0.20

degrees. Note the value of the thrust angle determined in this step.

4. Figure 7 shows a vehicle misaligned to the left of vehicle centerline. To correct this alignment problem, the rear tandem axle must be rotated clockwise. Figure 8 shows a vehicle misaligned to the right of vehicle centerline. To correct this alignment problem, the rear tandem axle must be rotated counterclockwise. The amount of misalignment will determine how much adjustment is required.
5. The following formulae determine exactly how much increase in shim thickness is needed to correct any thrust angle condition depending on the method of correction.

ONE BEAM END CORRECTION—REAR TANDEM AXLE

Thickness increase (inches) - $0.63 \times \text{Thrust Angle (degrees)}$

TWO BEAM END CORRECTION—REAR TANDEM AXLE

Thickness increase (inches) - $0.31 \times \text{Thrust Angle (degrees)}$

Use the thrust angle from step 3 in these formulae. Round the calculated thickness to the nearest 1/16". Table Nos. 1 and 2 provide a quick means of determining thickness increase versus thrust angle and sight distance. For those cases not shown in these

Figure 3—Various Orientations of 50130-000 Shim with 50160-000 Shim Type Bushing

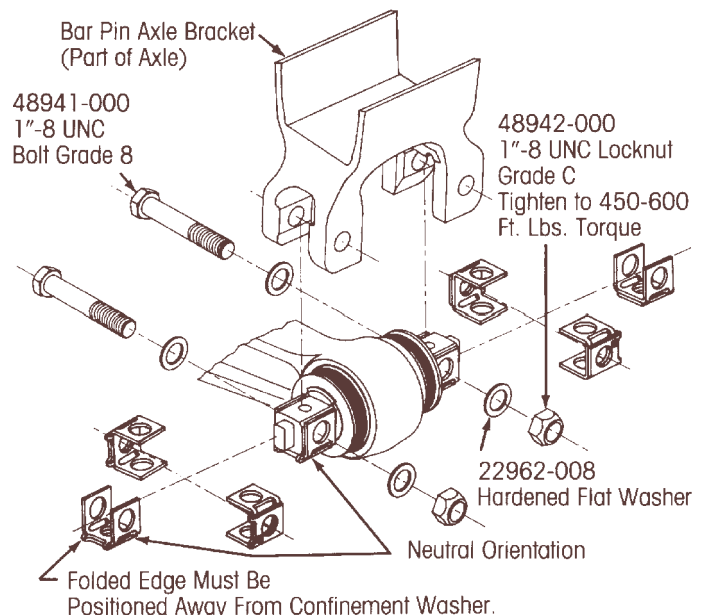



Table No. 1—Light Beam Offset/Thrust Angle/Shim Thickness Increase Clockwise Correction

Thrust Angle (°)	Sight Distance (IN)	Offset-1/4 in		Increase in Shim Thickness @ Location 1 and Location 2 See Fig. No. 7 (IN)		Sight Distance (IN)	Offset-1/2 in		Increase in Shim Thickness @ Location 1 and Location 2 See Fig. No. 7 (IN)	
		Increase in Shim Thickness @ Location 1 or Location 2 See Fig. No. 7 (IN)	-OR-	Increase in Shim Thickness @ Location 1 and Location 2 See Fig. No. 7 (IN)	-OR-		Increase in Shim Thickness @ Location 1 or Location 2 See Fig. No. 7 (IN)	-OR-	Increase in Shim Thickness @ Location 1 and Location 2 See Fig. No. 7 (IN)	
0.10	143.50	1/16	-	-	-	287.00	1/16	-	-	-
0.20	-	-	-	-	-	143.50	1/8	-OR-	1/16	-
0.30	-	-	-	-	-	-	-	-	-	-
0.40	-	-	-	-	-	-	-	-	-	-
Thrust Angle (°)	Sight Distance (IN)	Offset-3/4 in		Increase in Shim Thickness @ Location 1 and Location 2 See Fig. No. 7 (IN)		Sight Distance (IN)	Offset-1 in		Increase in Shim Thickness @ Location 1 and Location 2 See Fig. No. 7 (IN)	
		Increase in Shim Thickness @ Location 1 or Location 2 See Fig. No. 7 (IN)	-OR-	Increase in Shim Thickness @ Location 1 and Location 2 See Fig. No. 7 (IN)	-OR-		Increase in Shim Thickness @ Location 1 or Location 2 See Fig. No. 7 (IN)	-OR-	Increase in Shim Thickness @ Location 1 and Location 2 See Fig. No. 7 (IN)	
0.10	430.50	1/16	-	-	-	574.00	1/16	-	-	-
0.20	215.25	1/8	-OR-	1/16	-	287.00	1/8	-OR-	1/16	-
0.30	143.50	3/16	-	-	-	191.33	3/16	-	-	-
0.40	-	-	-	-	-	143.50	1/4	-OR-	1/8	-
Thrust Angle (°)	Sight Distance (IN)	Offset-1 1/4 in		Increase in Shim Thickness @ Location 1 and Location 2 See Fig. No. 7 (IN)		Sight Distance (IN)	Offset-1 1/2 in		Increase in Shim Thickness @ Location 1 and Location 2 See Fig. No. 7 (IN)	
		Increase in Shim Thickness @ Location 1 or Location 2 See Fig. No. 7 (IN)	-OR-	Increase in Shim Thickness @ Location 1 and Location 2 See Fig. No. 7 (IN)	-OR-		Increase in Shim Thickness @ Location 1 or Location 2 See Fig. No. 7 (IN)	-OR-	Increase in Shim Thickness @ Location 1 and Location 2 See Fig. No. 7 (IN)	
0.10	-	-	-	-	-	-	-	-	-	-
0.20	358.75	1/8	-OR-	1/16	-	-	-	-	-	-
0.30	239.16	3/16	-	-	-	287.00	3/16	-	-	-
0.40	179.37	1/4	-OR-	1/8	-	215.24	1/4	-OR-	1/8	-
0.50	143.49	-	-	-	-	-	-	-	-	-
0.60	-	-	-	-	-	143.49	3/8	-OR-	3/16	-
0.70	-	-	-	-	-	-	-	-	-	-
0.80	-	-	-	-	-	-	-	-	-	-
Thrust Angle (°)	Sight Distance (IN)	Offset-1 3/4 in		Increase in Shim Thickness @ Location 1 and Location 2 See Fig. No. 7 (IN)		Sight Distance (IN)	Offset-2 in		Increase in Shim Thickness @ Location 1 and Location 2 See Fig. No. 7 (IN)	
		Increase in Shim Thickness @ Location 1 or Location 2 See Fig. No. 7 (IN)	-OR-	Increase in Shim Thickness @ Location 1 and Location 2 See Fig. No. 7 (IN)	-OR-		Increase in Shim Thickness @ Location 1 or Location 2 See Fig. No. 7 (IN)	-OR-	Increase in Shim Thickness @ Location 1 and Location 2 See Fig. No. 7 (IN)	
0.10	-	-	-	-	-	-	-	-	-	-
0.20	-	-	-	-	-	-	-	-	-	-
0.30	-	-	-	-	-	-	-	-	-	-
0.40	251.12	1/4	-OR-	1/8	-	286.99	1/4	-OR-	1/8	-
0.50	-	-	-	-	-	-	-	-	-	-
0.60	167.41	3/8	-OR-	3/16	-	191.32	3/8	-OR-	3/16	-
0.70	143.49	-	-	-	-	-	-	-	-	-
0.80	-	-	-	-	-	143.49	-	-	1/4	-

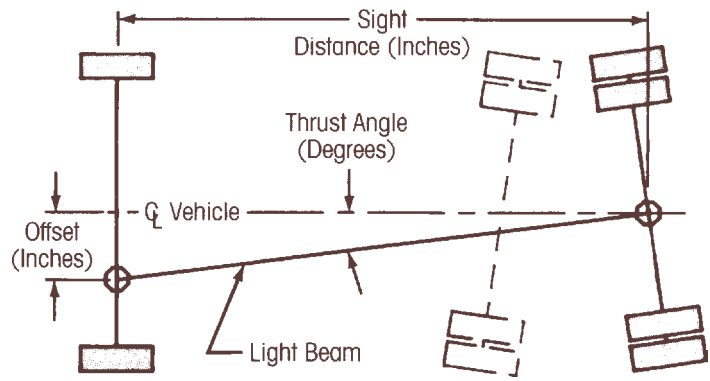
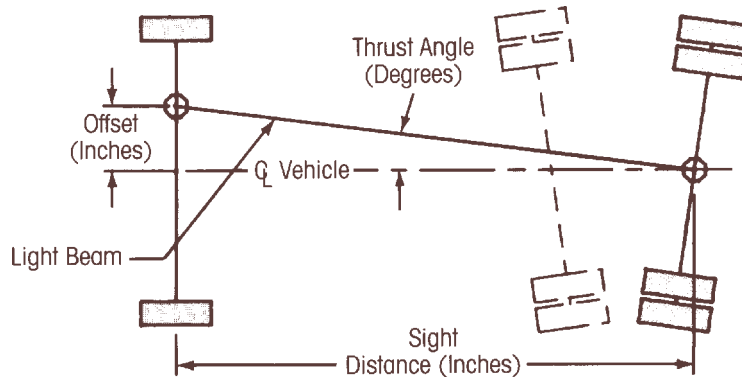



Table No. 2—Light Beam Offset/Thrust Angle/Shim Thickness Increase Counterclockwise Correction

Thrust Angle (°)	Offset-1/4 in				Offset-1/2 in			
	Sight Distance (IN)	Increase in Shim Thickness @ Location 3 or Location 4 See Fig. No. 8 (IN)	Increase in Shim Thickness @ Location 3 and Location 4 See Fig. No. 8 (IN)		Sight Distance (IN)	Increase in Shim Thickness @ Location 3 or Location 4 See Fig. No. 8 (IN)	Increase in Shim Thickness @ Location 3 and Location 4 See Fig. No. 8 (IN)	
0.10	143.50	1/16	-	-	287.00	1/16	-	-
0.20	-	-	-	-	143.50	1/8	-OR-	1/16
0.30	-	-	-	-	-	-	-	-
0.40	-	-	-	-	-	-	-	-
Thrust Angle (°)	Offset-3/4 in				Offset-1 in			
	Sight Distance (IN)	Increase in Shim Thickness @ Location 3 or Location 4 See Fig. No. 8 (IN)	Increase in Shim Thickness @ Location 3 and Location 4 See Fig. No. 8 (IN)		Sight Distance (IN)	Increase in Shim Thickness @ Location 3 or Location 4 See Fig. No. 8 (IN)	Increase in Shim Thickness @ Location 3 and Location 4 See Fig. No. 8 (IN)	
0.10	430.50	1/16	-	-	574.00	1/16	-	-
0.20	215.25	1/8	-OR-	1/16	287.00	1/8	-OR-	1/16
0.30	143.50	3/16	-	-	191.33	3/16	-	-
0.40	-	-	-	-	143.50	1/4	-OR-	1/8
Thrust Angle (°)	Offset 1 3/4 in				Offset- 1 1/2 in			
	Sight Distance (IN)	Increase in Shim Thickness @ Location 3 or Location 4 See Fig. No. 8 (IN)	Increase in Shim Thickness @ Location 3 and Location 4 See Fig. No. 8 (IN)		Sight Distance (IN)	Increase in Shim Thickness @ Location 3 or Location 4 See Fig. No. 8 (IN)	Increase in Shim Thickness @ Location 3 and Location 4 See Fig. No. 8 (IN)	
0.10	-	-	-	-	-	-	-	-
0.20	358.75	1/8	-OR-	1/16	-	-	-	-
0.30	239.16	3/16	-	-	287.00	3/16	-	-
0.40	179.37	1/4	-OR-	1/8	215.24	1/4	-OR-	1/8
0.50	143.49	-	-	-	-	-	-	-
0.60	-	-	-	-	143.49	3/8	-OR-	3/16
0.70	-	-	-	-	-	-	-	-
0.80	-	-	-	-	-	-	-	-
Thrust Angle (°)	Offset-1 3/4 in				Offset-2 in			
	Sight Distance (IN)	Increase in Shim Thickness @ Location 3 or Location 4 See Fig. No. 8 (IN)	Increase in Shim Thickness @ Location 3 and Location 4 See Fig. No. 8 (IN)		Sight Distance (IN)	Increase in Shim Thickness @ Location 3 or Location 4 See Fig. No. 8 (IN)	Increase in Shim Thickness @ Location 3 and Location 4 See Fig. No. 8 (IN)	
0.10	-	-	-	-	-	-	-	-
0.20	-	-	-	-	-	-	-	-
0.30	-	-	-	-	-	-	-	-
0.40	251.12	1/4	-OR-	1/8	286.99	1/4	-OR-	1/8
0.50	-	-	-	-	-	-	-	-
0.60	167.41	3/8	-OR-	3/16	191.32	3/8	-OR-	3/16
0.70	143.49	-	-	-	-	-	-	-
0.80	-	-	-	-	143.49	-	-	1/4





Subject 5 (Continued)

ALIGNMENT REAR TANDEM AXLE

tables, the above formulae must be used. Figure 7 & 8 show you where the shim thickness must be increased to correct any thrust angle condition.

6. Before the actual correction procedure can begin, you must know the "before adjustment" shim part number and orientation at the beam end(s) requiring adjustment. Inspect the vehicle and relate the actual vehicle shim part number and orientation to Figure 3, 4 or 5 to determine the "before adjustment" shim thickness at the beam end(s).
7. Add the thickness increase from step 5 to the "before adjustment" shim thickness determined in step 6. This will give you the "after adjustment" shim thickness which is to be installed on the vehicle to correct the thrust angle misalignment.
8. See Figure 3, 4 or 5 to find the "after adjustment" shim part number and orientation which best fits the required "after adjustment" shim thickness. The shims should be placed on the bushing assembly as shown in one of these figures according to the method of correction chosen in step 7. Use genuine Hendrickson shims, part number 50130-000, 50131-000 or 57026-000, to make the adjustment. Figure 6 shows an isometric view of each genuine Hendrickson shim. Note the part numbers and material thickness stamped on each shim leg.

WARNING: A SHIM MUST BE INSTALLED AT EACH BOLT LOCATION. THE SAME PART NUMBER SHIM IN THE SAME ORIENTATION MUST BE USED AT BOTH BOLT LOCATIONS ON ANY ONE BUSHING ASSEMBLY. DO NOT INSTALL OR STACK MORE THAN ONE SHIM AT EACH BOLT LOCATION. USE GENUINE HENDRICKSON SHIMS, DO NOT USE STANDARD WASHERS. THE FAILURE TO FOLLOW THESE WARNINGS MAY RESULT IN THE FRACTURE OF EITHER THE BRACKET OR BAR PIN WHICH COULD RESULT IN THE LOSS OF VEHICLE CONTROL AND POSSIBLE PERSONAL INJURY OR PROPERTY DAMAGE.

9. Examples of thrust angle correction are provided in Example Nos. 1-4.
10. Take the necessary precautions to prevent the vehicle from rolling.
11. Disconnect the upper torque rods at either the vehicle frame or the axle end.

Figure 4—Various Orientations of 50131-000 Shim with 50160-000 Shim Type Bushing

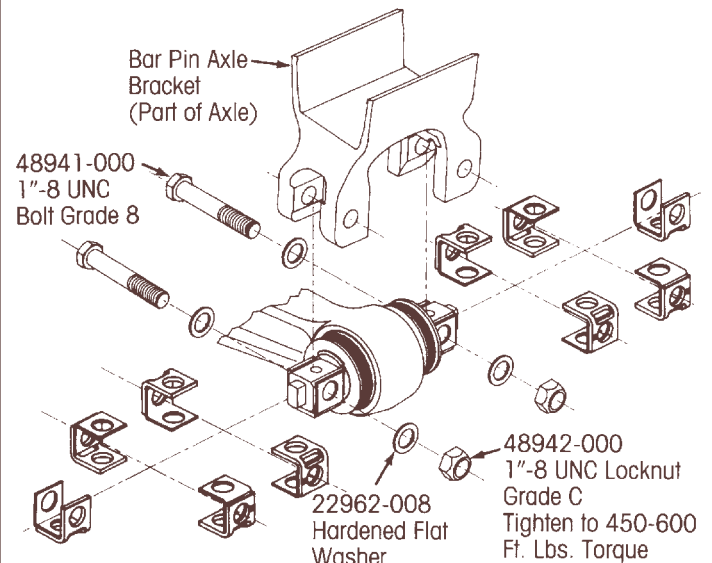

Figure 5—Various Orientations of 57026-000 Shim with 50160-000 Shim Type Bushing

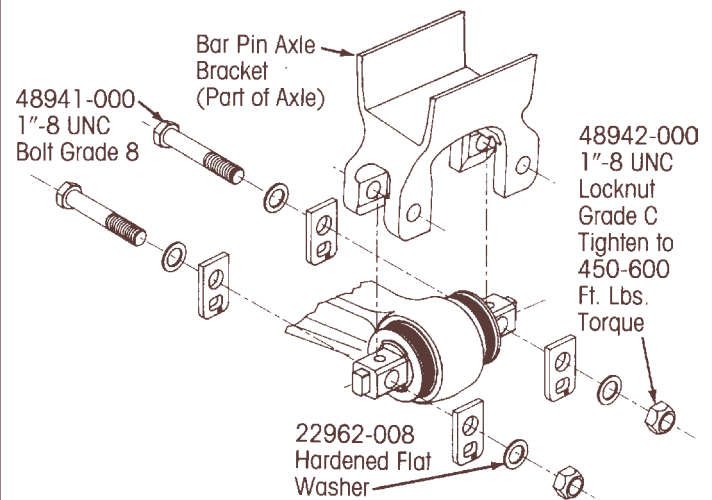
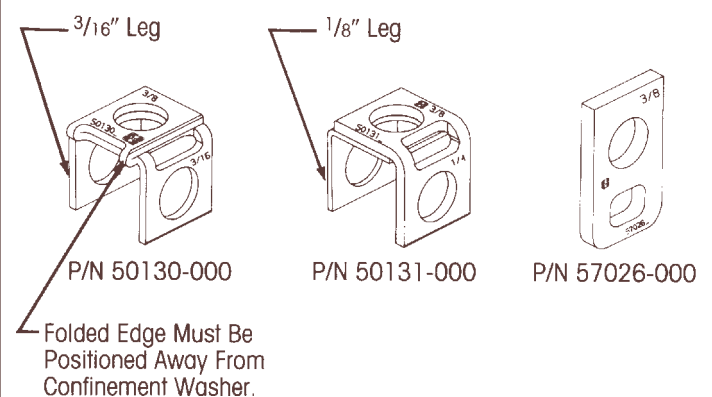

Figure 6





Subject 5 (Continued)

ALIGNMENT REAR TANDEM AXLE

12. Remove the weight from the tandem axles by jacking at the rear of the vehicle frame. See Figure 9.
13. Remove both 1" bolts from the bar pin beam end connection(s) that requires adjustment to correct the thrust angle misalignment. Most vehicle conditions can be corrected by adjusting only one beam end connection.
14. There are two methods which can be used to gain access to the shims for adjustment.

Method 1: Remove the four (4) nuts from the saddle cap studs on the side of the vehicle that is to be adjusted. Slowly lower the jack at the rear of the vehicle frame. The end of the beam should drop free of the axle bracket. If the beam end does not drop free, a bar inserted and pried between the beam end and the axle housing should help.

Figure 7—Clockwise Thrust Angle Correction

Note: For correction requiring that only one shim be changed, the change in thickness can occur at either location ① or ②. For correction requiring that two shims be changed, the change in thickness will occur at both locations ① and ②.

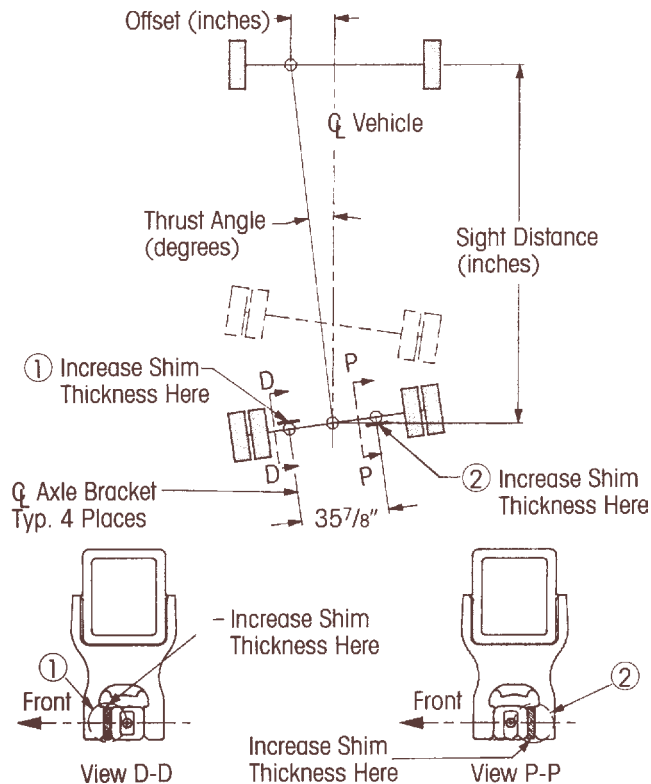

Method 1 (Continued)

Another means of dropping the beam end is to insert a bottle jack between the vehicle frame and the beam and jack downward until the beam drops.

See Method 2 on page 13.

Figure 8—Counterclockwise Out-of-parallel Correction

Note: For correction requiring that only one shim be changed, the change in thickness can occur at either location ③ or ④. For correction requiring that two shims be changed, the change in thickness will occur at both locations ③ and ④.

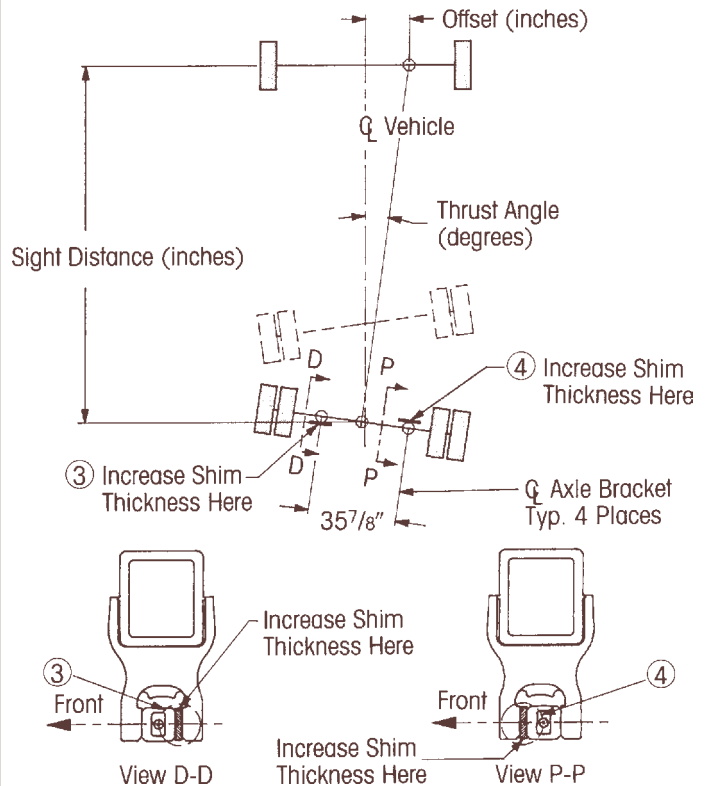
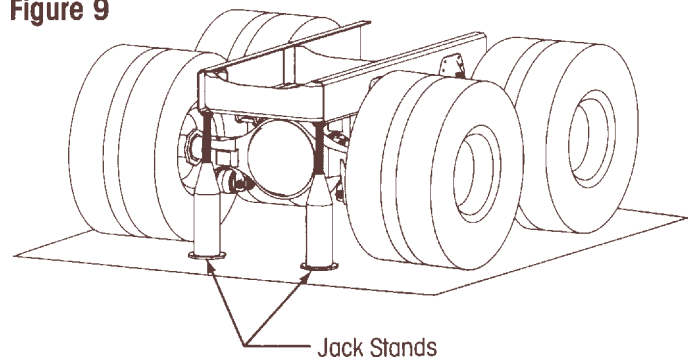
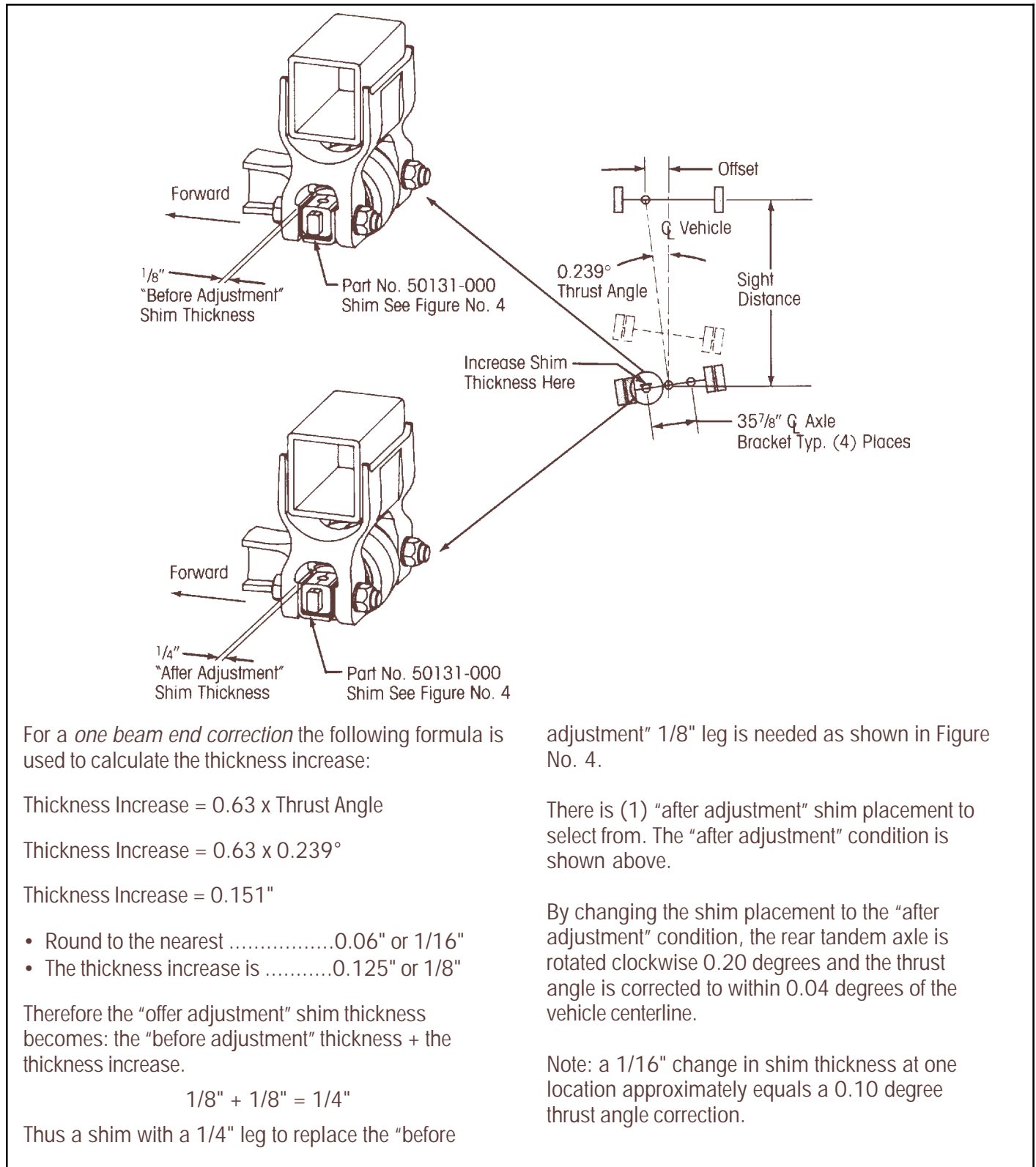

Figure 9





Example No. 1—Clockwise Thrust Angle Correction/One Beam End Correction





Example No. 2—Clockwise Thrust Angle Correction/Two Beam End Correction

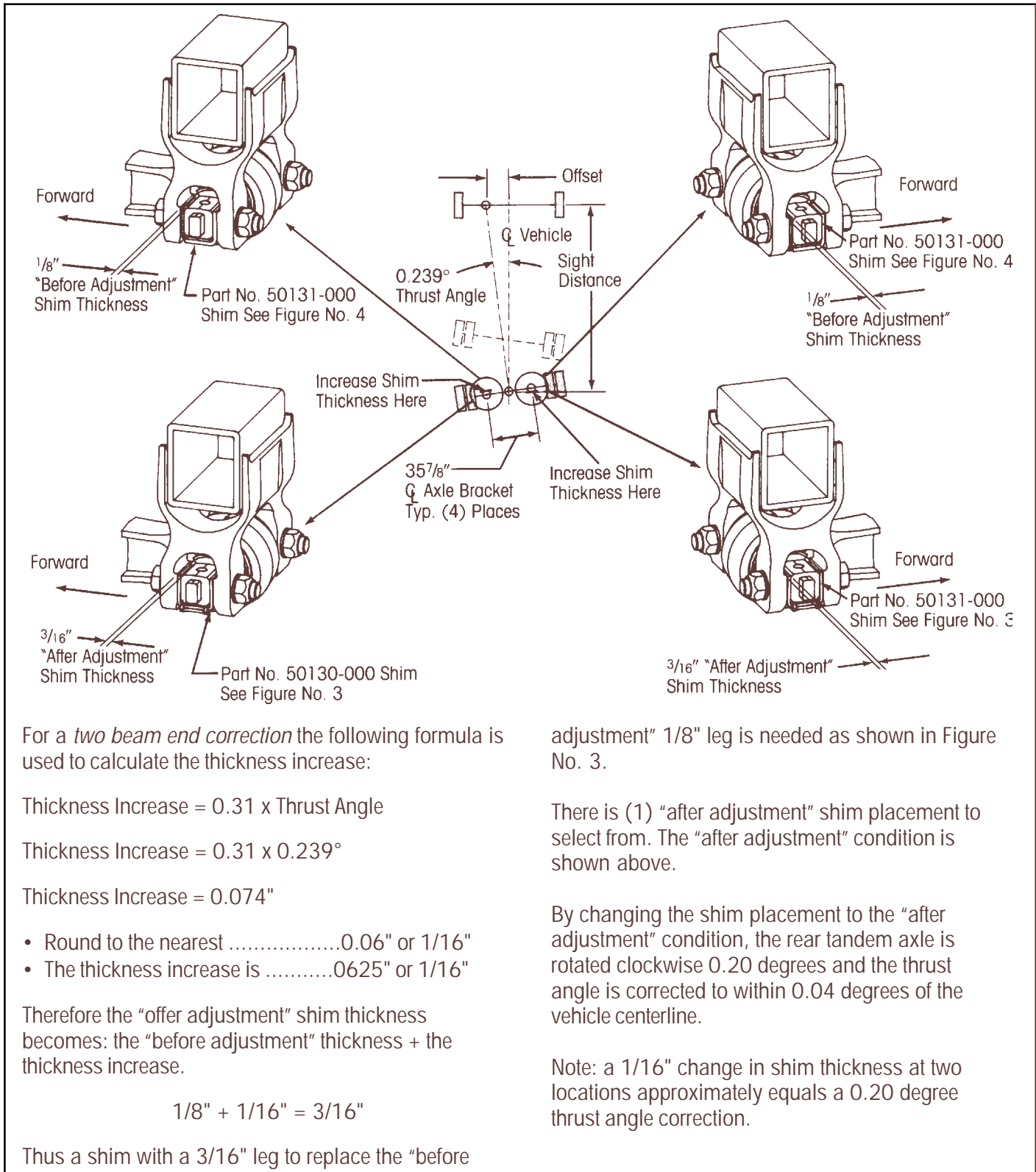

For a *two beam end correction* the following formula is used to calculate the thickness increase:

$$\text{Thickness Increase} = 0.31 \times \text{Thrust Angle}$$

$$\text{Thickness Increase} = 0.31 \times 0.239^\circ$$

$$\text{Thickness Increase} = 0.074"$$

- Round to the nearest0.06" or 1/16"
- The thickness increase is0625" or 1/16"

Therefore the "offer adjustment" shim thickness becomes: the "before adjustment" thickness + the thickness increase.

$$1/8" + 1/16" = 3/16"$$

Thus a shim with a 3/16" leg to replace the "before

adjustment" 1/8" leg is needed as shown in Figure No. 3.

There is (1) "after adjustment" shim placement to select from. The "after adjustment" condition is shown above.

By changing the shim placement to the "after adjustment" condition, the rear tandem axle is rotated clockwise 0.20 degrees and the thrust angle is corrected to within 0.04 degrees of the vehicle centerline.

Note: a 1/16" change in shim thickness at two locations approximately equals a 0.20 degree thrust angle correction.



Example No. 3—Counterclockwise Thrust Angle Correction/One Beam End Correction

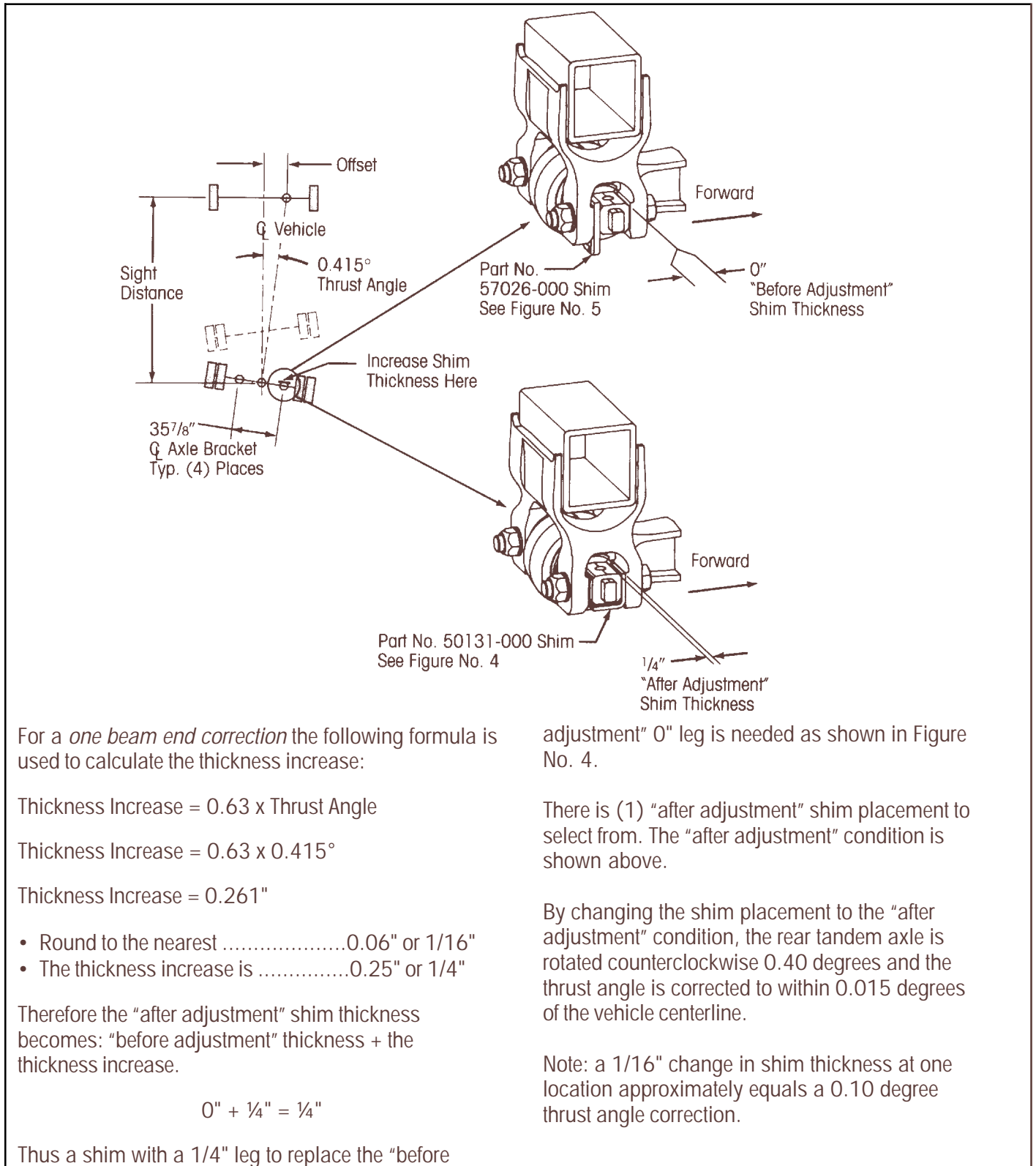

For a *one beam end correction* the following formula is used to calculate the thickness increase:

$$\text{Thickness Increase} = 0.63 \times \text{Thrust Angle}$$

$$\text{Thickness Increase} = 0.63 \times 0.415^\circ$$

$$\text{Thickness Increase} = 0.261"$$

- Round to the nearest0.06" or 1/16"
- The thickness increase is0.25" or 1/4"

Therefore the "after adjustment" shim thickness becomes: "before adjustment" thickness + the thickness increase.

$$0" + \frac{1}{4}" = \frac{1}{4}"$$

Thus a shim with a 1/4" leg to replace the "before

adjustment" 0" leg is needed as shown in Figure No. 4.

There is (1) "after adjustment" shim placement to select from. The "after adjustment" condition is shown above.

By changing the shim placement to the "after adjustment" condition, the rear tandem axle is rotated counterclockwise 0.40 degrees and the thrust angle is corrected to within 0.015 degrees of the vehicle centerline.

Note: a 1/16" change in shim thickness at one location approximately equals a 0.10 degree thrust angle correction.



Example No. 4—Counterclockwise Thrust Angle Correction/Two Beam End Correction

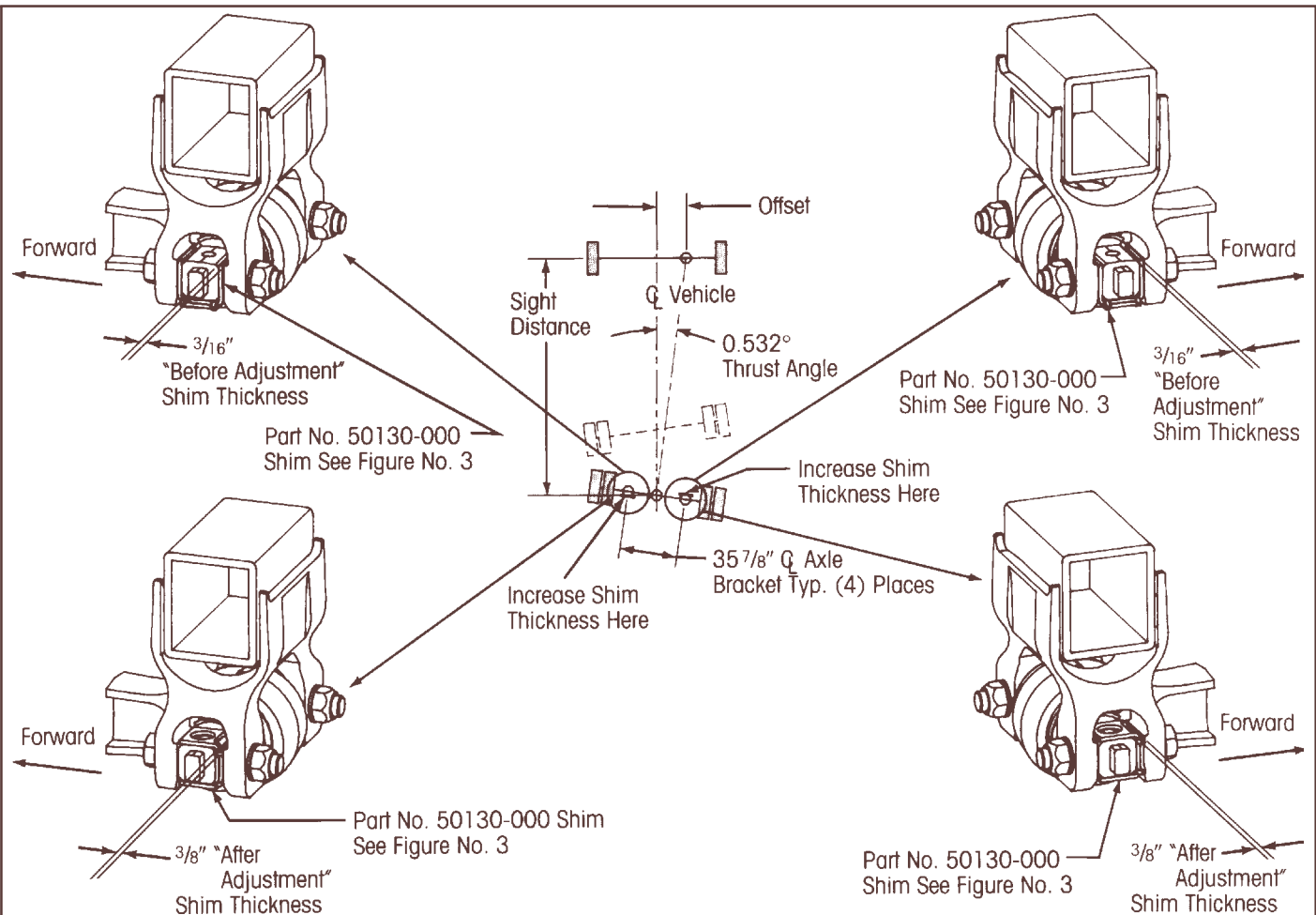

For a *two beam end correction* the following formula is used to calculate the thickness increase:

$$\text{Thickness Increase} = 0.31 \times \text{Thrust Angle}$$

$$\text{Thickness Increase} = 0.31 \times 0.532^\circ$$

$$\text{Thickness Increase} = 0.165''$$

- Round to the nearest0.06" or 1/16"
- The thickness increase is0.1875" or 3/16"

Therefore the "after adjustment" shim thickness becomes: the "before adjustment" thickness + the thickness increase.

$$3/16'' + 3/16'' = 3/8''$$

Thus a shim with a 3/8" leg to replace the "before

adjustment" 3/16" leg is needed as shown in Figure Nos. 3, 4 & 5.

There are (4) "after adjustment" shim placements to select from. The "after adjustment" condition that we selected is shown above.

By changing the shim placement to the "after adjustment" condition, the rear tandem axle is rotated counterclockwise 0.60 degrees and the thrust angle is corrected to within 0.07 degrees of the vehicle centerline.

Note: a 1/16" change in shim thickness at two locations approximately equals a 0.20 degree thrust angle correction.



Subject 5 (Continued)
ALIGNMENT REAR TANDEM AXLE

WARNING: IF THIS METHOD IS USED, DO NOT GOUGE OR NICK THE BEAM FLANGES WITH THE JACK. GOUGED OR NICKED BEAM FLANGES MAY CAUSE A BEAM FRACTURE, POSSIBLE LOSS OF VEHICLE CONTROL AND POSSIBLE PERSONAL INJURY OR PROPERTY DAMAGE.

Method 2: The shims can also be removed without dropping the beam end. To remove the shims, it is necessary to closely match the angle on the bar pin casting with the angle of the legs on the axle bracket. By matching these angles, the preload or pinching action on the shim is relaxed and the shims can be removed. These angles can be matched by jacking against the bottom of the axle differential carrier or by gripping the wrenching flats on one end of the bar pin casting with a wrench or user designed installation tools. A screwdriver and/or a pair of pliers can then be used to grab the shim and remove it.

15. Reassemble the shims to the bar pin beam end connection that is being adjusted. If the beam end was dropped from the axle bracket, it must be jacked back up into the axle bracket. This is easily done by placing a small bottle jack under the beam and jacking against the floor. If the beam end remained in place within the axle bracket, the shims are slipped by hand into the gap(s) between the axle bracket and the bar pin casting. Again, proper angular alignment between the axle bracket legs and the bar pin casting should be maintained to permit easy insertion of the shims. In either case, the shims must be positioned to match the required "after adjustment" shim placement as shown in Figure 3, 4 or 5. This was determined in step 7.

WARNING: A SHIM MUST BE INSTALLED AT EACH BOLT LOCATION. THE SAME PART NUMBER SHIM IN THE SAME ORIENTATION MUST BE USED AT BOTH BOLT LOCATIONS ON ANY ONE BUSHING ASSEMBLY. DO NOT INSTALL OR STACK MORE THAN ONE SHIM AT EACH BOLT LOCATION. USE GENUINE HENDRICKSON SHIMS, DO NOT USE STANDARD WASHERS. THE FAILURE TO FOLLOW THESE WARNINGS MAY RESULT IN THE FRACTURE OF EITHER THE BRACKET OR BAR

PIN WHICH COULD RESULT IN THE LOSS OF VEHICLE CONTROL AND POSSIBLE PERSONAL INJURY OR PROPERTY DAMAGE.

16. When the beam end connection holes align with the axle bracket holes, install new 1" bolts, new 1" washers and new 1" locknuts. Tighten the locknuts to 450-600 ft. lbs. torque. The bolts are to be inserted from the centerline of the tandem axle to the outside. See Figure No. 10.
17. Recheck the thrust angle to insure that the proper adjustment has been made. Repeat steps 1 through 17 of this subject if necessary. The thrust angle correction should be complete.

Subject 6
ADJUSTMENT FRONT TANDEM AXLE

The following procedure is recommended for correcting the spacing between tandem axles after the thrust angle is corrected on the rear tandem axle.

1. First determine axle spacing by means of a tape measure, trammel bar or direct computer readout. Record axle spacings on driver and passenger

Figure 10

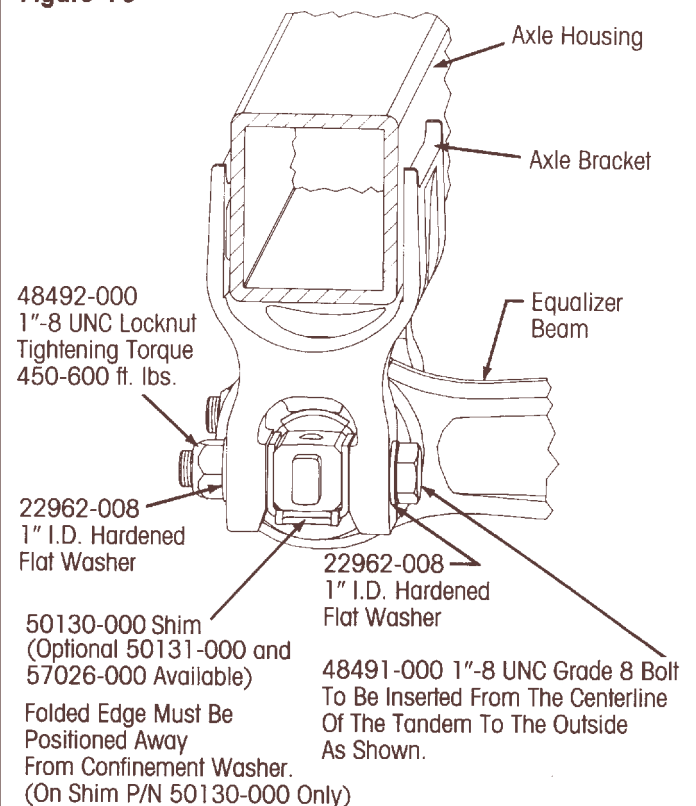



Subject 6 (Continued)

ADJUSTMENT FRONT TANDEM AXLE

sides of the vehicle. Determine the difference in axle spacing from side to side.

2. If the axle spacing difference is less than 3/16", do nothing.
3. If the axle spacing difference equals or exceeds 3/16", the following procedure is recommended.
4. The vehicle shown in Figure 11 requires a clockwise front tandem axle rotation to correct the non-parallel axle condition. The vehicle shown in Figure 12 requires a counterclockwise front tandem axle rotation to correct the non-parallel axle condition. The amount of parallel misalignment will determine how much adjustment is required.
5. The following formulae determine exactly how much increase in shim thickness is needed to correct any tandem axle non-parallel condition.

ONE BEAM END CORRECTION—FRONT TANDEM AXLE

Thickness increase (inches) = $0.374 \times$ Difference between tandem axle spacing on passenger and driver sides (inches)

TWO BEAM END CORRECTION—FRONT TANDEM AXLE

Thickness increase (inches) = $0.187 \times$ Difference between tandem axle spacing on passenger and driver sides (inches)

Round the calculated thickness increase to the nearest 1/16". Table Nos. 3 and 4 provide a quick means of determining thickness increase versus tandem axle out-of-parallel measurement. For those cases not shown in these tables, the above formulae must be used. Figure 11 and 12 show where the shim thickness must be increased to correct any tandem axle non-parallel condition.

Figure 11—Clockwise Out-of-parallel Correction

Note: For correction requiring that only one shim be changed, the change in thickness can occur at either location ⑤ or ⑥. For correction requiring that two shims be changed, the change in thickness will occur at both locations ⑤ and ⑥.

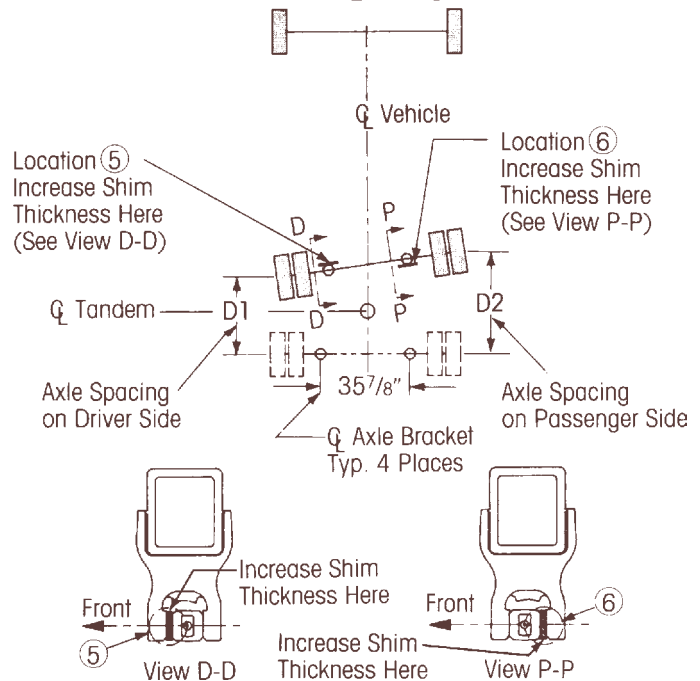

Figure 12—Counterclockwise Out-of-parallel Correction

Note: For correction requiring that only one shim be changed, the change in thickness can occur at either location ⑦ or ⑧. For correction requiring that two shims be changed, the change in thickness will occur at both locations ⑦ and ⑧.

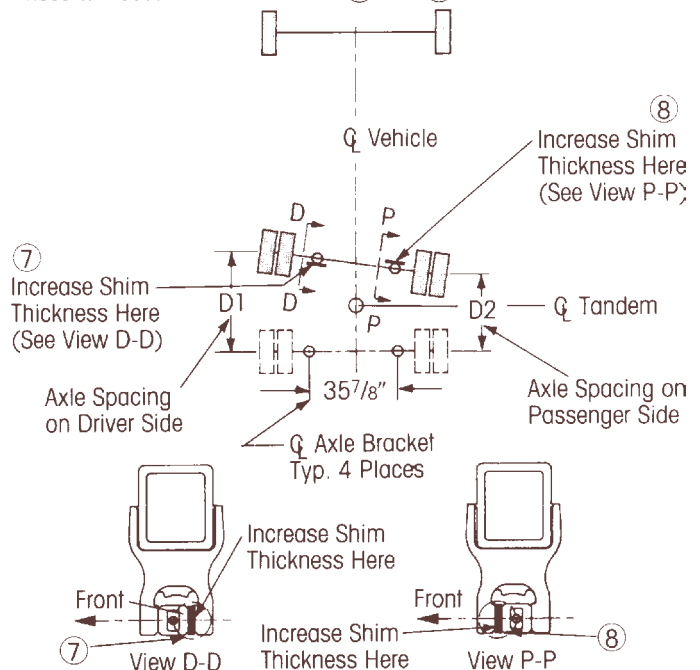



Table No. 3—Axle Spacing/Shim Thickness Clockwise Correction

Tandem Axles Out of Parallel by (IN)	Increase in Shim Thickness @ Location 5 or Location 6 See Fig. No. 11 (IN)	Increase in Shim Thickness @ Location 5 and Location 6 See Fig No. 11 (IN)	
0	-	-	
1/16	-	-	
1/8	-	-	
3/16	1/16	-	
1/4	-	-	
5/16	1/8	-OR- 1/16	
3/8	-	-	
7/16	-	-	
1/2	3/16	-	
9/16	-	-	
5/8	-	-	
11/16	1/4	-OR- 1/8	
3/4	-	-	
13/16	-	-	
7/8	-	-	
15/16	-	-	
1	3/8	-OR- 3/16	
1 1/16	-	-	
1 1/8	-	-	
1 3/16	-	-	
1 1/4	-	-	

Table No. 4—Axle Spacing/Shim Thickness Counterclockwise Correction

Tandem Axles Out of Parallel by (IN)	Increase in Shim Thickness @ Location 7 or Location 8 See Fig. No. 12 (IN)	Increase in Shim Thickness @ Location 7 and Location 8 See Fig No. 12 (IN)	
0	-	-	
1/16	-	-	
1/8	-	-	
3/16	1/16	-	
1/4	-	-	
5/16	1/8	-OR- 1/16	
3/8	-	-	
7/16	-	-	
1/2	3/16	-	
9/16	-	-	
5/8	-	-	
11/16	1/4	-OR- 1/8	
3/4	-	-	
13/16	-	-	
7/8	-	-	
15/16	-	-	
1	3/8	-OR- 3/16	
1 1/16	-	-	
1 1/8	-	-	
1 3/16	-	-	
1 1/4	-	-	



Example No. 5—Clockwise Out-of-parallel Correction/One Beam End Correction

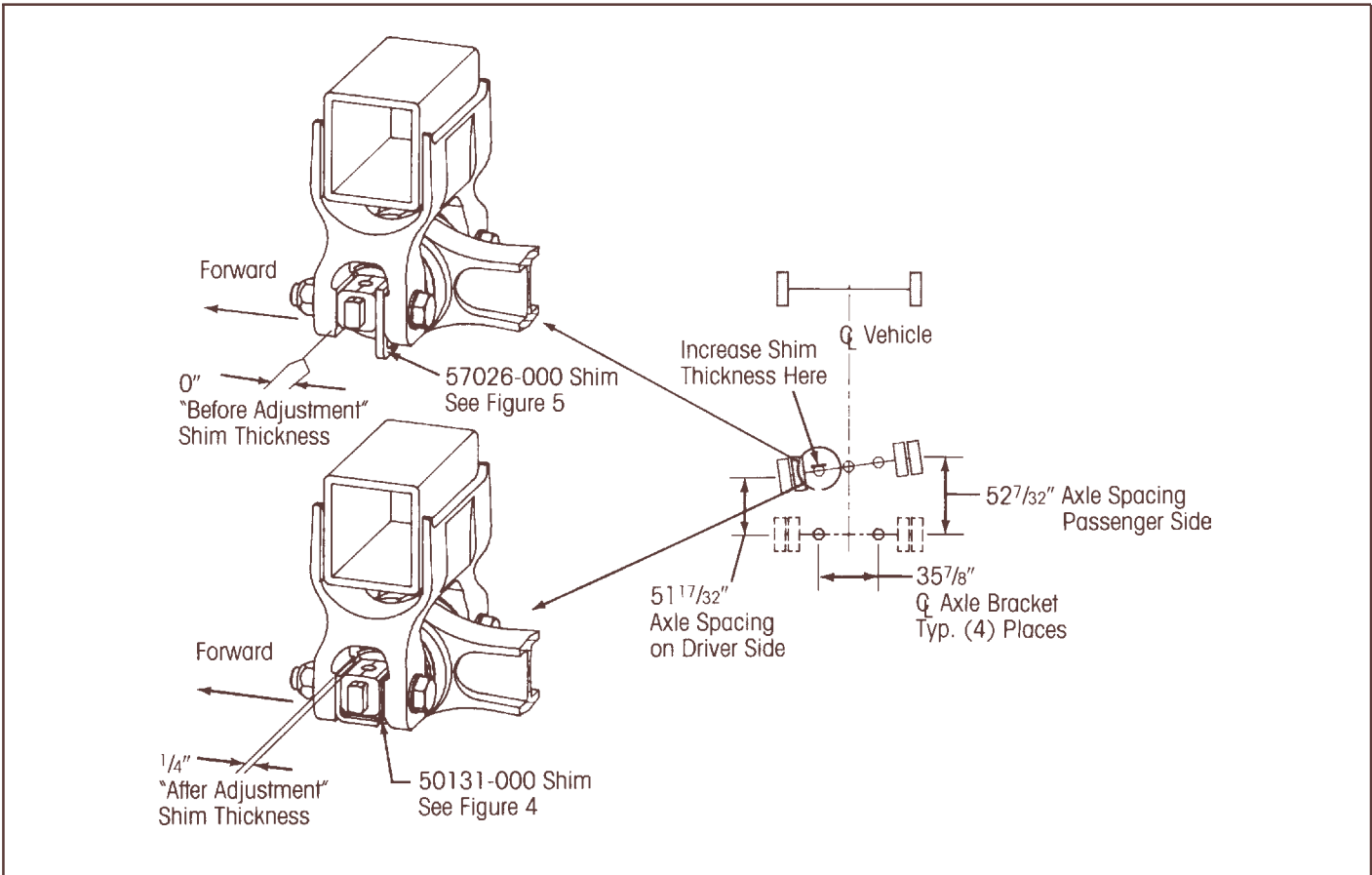

For a *one beam end correction* the following formula is used to calculate the thickness increase:

$$\text{Thickness Increase} = 0.374 \times \text{Difference between tandem axle spacing on passenger \& driver sides}$$

$$\text{Thickness Increase} = 0.374 \times (52 \frac{7}{32} - 51 \frac{17}{32})$$

$$\text{Thickness Increase} = 0.374 \times (\frac{11}{16})$$

$$\text{Thickness Increase} = 0.374 \times (0.6875)$$

$$\text{Thickness Increase} = 0.257"$$

- Round to the nearest0.06" or 1/16"
- The thickness increase is0.25" or 1/4"

Therefore the "offer adjustment" shim thickness becomes: "before adjustment" thickness + the thickness increase. $0" + 1/4" = 1/4"$

Thus a shim with a 1/4" leg to replace the "before adjustment" 0" leg is needed as shown in Figure No. 4.

There is (1) "after adjustment" shim placement to select from. The "after adjustment" condition is shown above.

By changing the shim placement to the "after adjustment" condition, the front tandem axle is rotated clockwise and the axle misalignment is corrected to within 0.02" of true parallel with the rear tandem axle.

Note: a 1/16" change in shim thickness at one location approximately equals a 0.167" out-of-parallel correction as measured at the wheel ends.



Example No. 6—Clockwise Out-of-parallel Correction/Two Beam End Correction

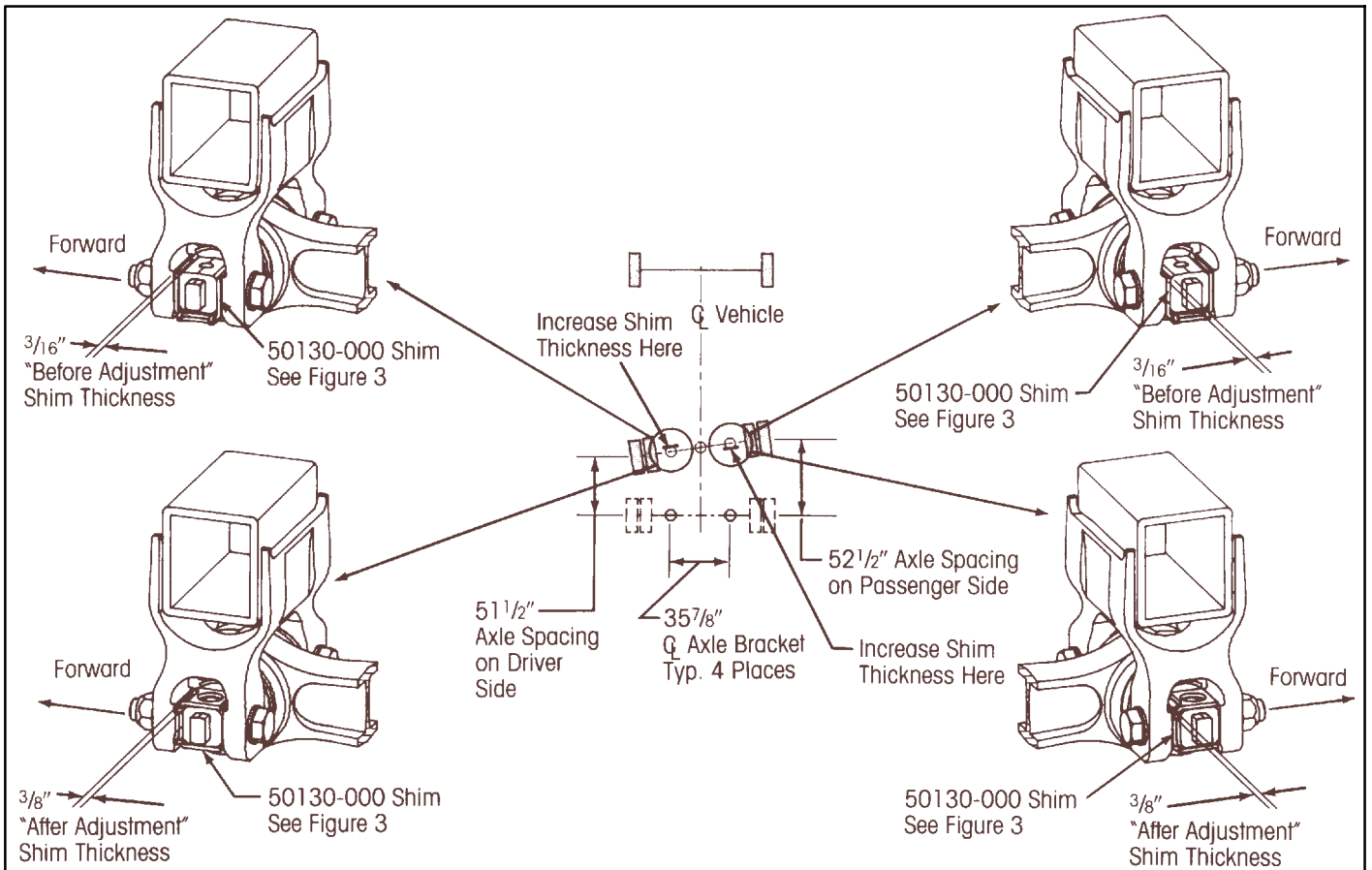

For a *two beam end correction* the following formula is used to calculate the thickness increase:

Thickness Increase $0.187 \times$ Difference between tandem axle spacing on passenger and driver sides

$$\text{Thickness Increase} = 0.187 \times (52\frac{1}{2} - 51\frac{1}{2})$$

$$\text{Thickness Increase} = 0.187 \times 1$$

$$\text{Thickness Increase} = 0.187"$$

- Round to the nearest0.06" or 1/16"
- The thickness increase is0.188" or 3/16"

Therefore the "after adjustment" shim thickness becomes: the "before adjustment" thickness + the thickness increase. $3/16" + 3/16" = 3/8"$

Thus a shim with a 3/8" leg to replace the "before adjustment" 3/16" is needed as shown in Figure Nos. 3, 4 & 5.

There are (4) "after adjustment" shim placements to select from. The "after adjustment" condition that we selected is shown above.

By changing the shim placement to the "after adjustment" condition, the front tandem axle is rotated clockwise and the axle misalignment is corrected to within 0.006" of true parallel with the rear tandem axle.

Note: a 1/16" change in shim thickness at two locations approximately equals a 0.334" out-of-parallel correction as measured at the wheel ends.



Example No. 7—Counterclockwise Out-of-parallel Correction/One Beam End Correction

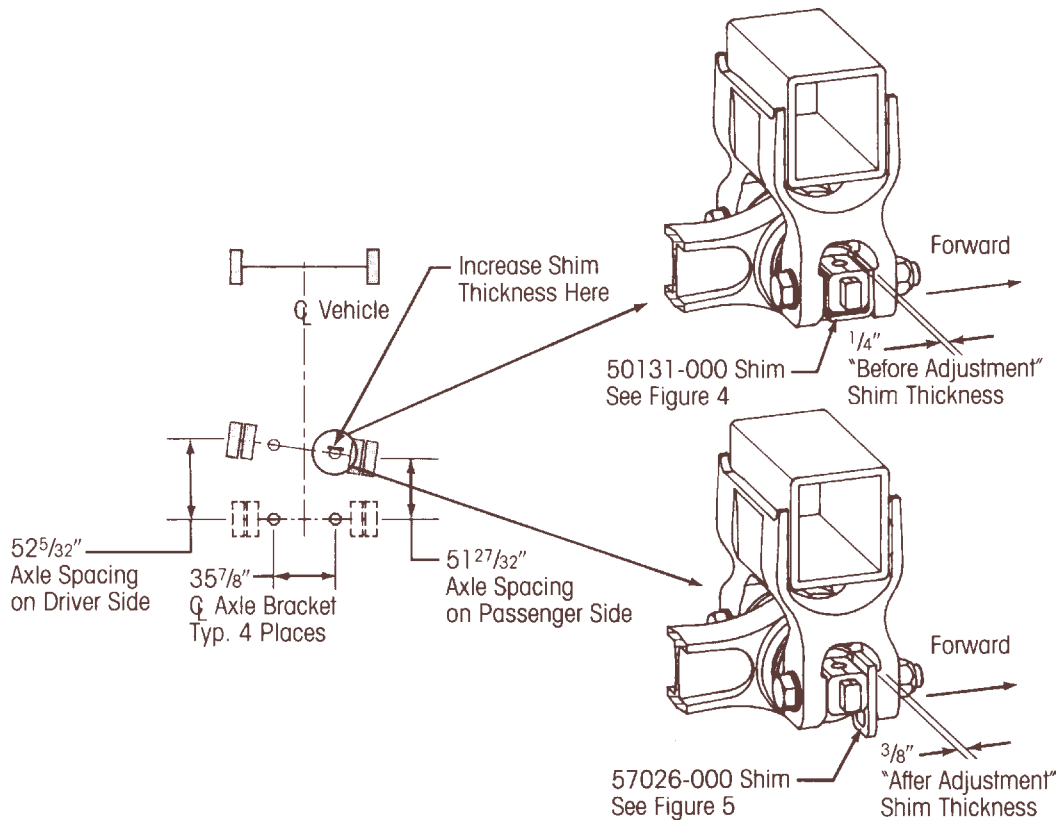

$$1/4" + 1/8" = 3/8"$$

For a *one beam end correction* the following formula is used to calculate the thickness increase:

Thickness Increase = 0.374 x Difference between tandem axle spacing on passenger and driver sides

$$\text{Thickness Increase} = 0.374 \times (52 \frac{5}{32} - 51 \frac{27}{32})$$

$$\text{Thickness Increase} = 0.374 \times (5/16)$$

$$\text{Thickness Increase} = 0.374 \times (.3125)$$

$$\text{Thickness Increase} = 0.117"$$

- Round to the nearest0.06" or 1/16"
- The thickness increase is0.125" or 1/8"

Therefore the "offer adjustment" shim thickness becomes:
"before adjustment" thickness + the thickness increase.

Thus a shim with a 3/8" leg to replace the "before adjustment" 1/4" is needed as shown in Figure Nos. 3, 4 & 5.

There is (1) "offer adjustment" shim placement to select from. The "after adjustment" condition is shown above.

By changing the shim placement to the "after adjustment" condition, the front tandem axle is rotated counterclockwise and the axle misalignment is corrected to within 0.02" of true parallel with the rear tandem axle.

Note: a 1/16" change in shim thickness at one location approximately equals a 0.167" out-of-parallel correction as measured at the wheel ends.



Example No. 8—Counterclockwise Out-of-parallel Correction/Two Beam End Correction

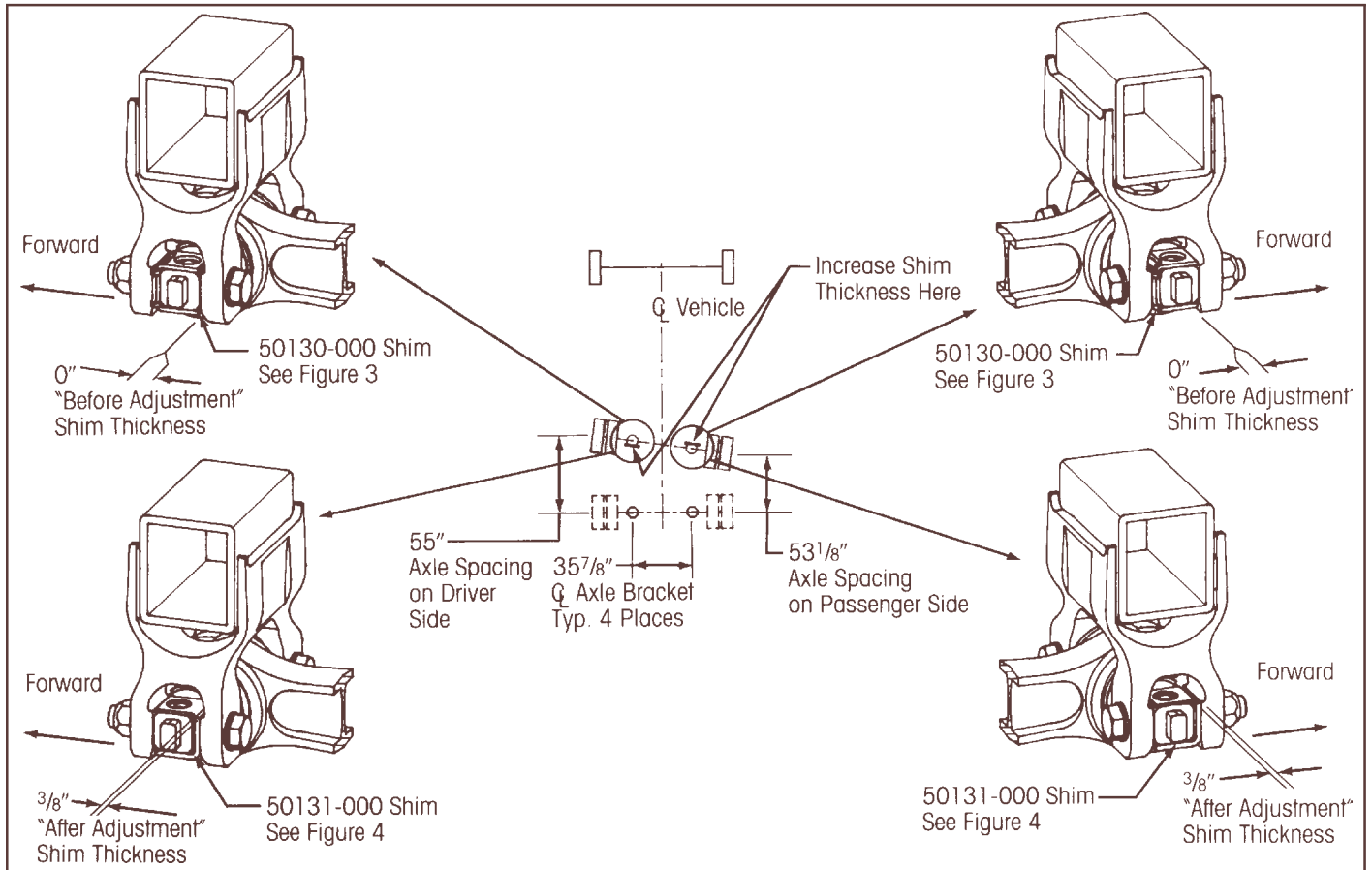

For a *two beam end correction* the following formula is used to calculate the thickness increase:

Thickness Increase = 0.187 x Difference between tandem axle spacing on passenger & driver sides

Thickness Increase = 0.187 x (55 - 53 1/8)

Thickness Increase = 0.187 x (17/8)

Thickness Increase = 0.187 x (1.875)

Thickness Increase = 0.351"

- Round to the nearest0.06" or 1/16"
- The thickness increase is0.375" or 3/8"

Therefore the "after adjustment" shim thickness becomes: "before adjustment" thickness + the thickness increase.

$$0" + 3/8" = 3/8"$$

Thus a shim with a 3/8" leg to replace the "before adjustment" 0" is needed as shown in Figure Nos. 3, 4 and 5.

There are (4) "offer adjustment" shim placements to select from. The "after adjustment" condition that we selected is shown above.

By changing the shim placement to the "after adjustment" condition, the front tandem axle is rotated counterclockwise and the axle misalignment is corrected to within 0.130" of true parallel with the rear tandem axle.

Note: a 1/16" change in shim thickness at two locations approximately equals a 0.334" out-of-parallel correction as measured at the wheel ends.



Subject 6 (Continued)

ADJUSTMENT FRONT TANDEM AXLE

6. Before the actual correction procedure can begin, you must know the "before adjustment" shim part number and orientation at the beam end(s) requiring adjustment. Inspect the vehicle and relate the actual vehicle shim part number and orientation to Figure 3, 4 or 5 to determine the "before adjustment" shim thickness at the beam end(s).
7. Add the thickness increase from step 5 of this subject to the "before adjustment" shim thickness determined in step 6 of this subject. This will give you the "after adjustment" shim thickness which is to be installed on the vehicle to correct the axle non-parallel condition.
8. See Figure 3, 4 or 5 to find the "after adjustment" shim part number and orientation which best fits the required "after adjustment" shim thickness. The shims should be placed on the bushing assembly as shown in one of these figures according to the method of correction chosen in step 5 of this subject. Use genuine Hendrickson shims, part number 50130-000, 50131-000 or 57026-000, to make the adjustment. Figure 6 shows an isometric view of each genuine Hendrickson shim. Note the part numbers and material thickness stamped on each shim leg.
9. Examples of front tandem axle non-parallel correction are provided in Example Nos. 5-8.
10. Loosen and remove the 1" bolts at the beam to axle connection(s) which requires adjustment. Remove the shim(s) from the beam end/axle bracket connection(s). Follow the procedure in step 14 of subject 5 as necessary.
11. Reassemble the shims to the bar pin beam end connection that requires adjustment. If the beam end was dropped from the axle bracket, the beam end must be jacked back up into the axle bracket. This is easily done by placing a small bottle jack under the beam end and jacking against the floor. If the beam end remained in place within the axle bracket, the shims are slipped by hand back into the gap(s) between the axle bracket and the bar pin

casting. Again, the proper angular alignment between the axle bracket legs and the bar pin casting should be maintained to permit easy insertion of the shims. In either case, the shims must be positioned to match the required "after adjustment" shim placement as found on Figure 3, 4 or 5. This was determined in step 7.

WARNING: A SHIM MUST BE INSTALLED AT EACH BOLT LOCATION. THE SAME PART NUMBER SHIM IN THE SAME ORIENTATION MUST BE USED AT BOTH BOLT LOCATIONS ON ANY ONE BUSHING ASSEMBLY. DO NOT INSTALL OR STACK MORE THAN ONE SHIM AT EACH BOLT LOCATION. USE GENUINE HENDRICKSON SHIMS, DO NOT USE STANDARD WASHERS. THE FAILURE TO FOLLOW THESE WARNINGS MAY RESULT IN THE FRACTURE OF EITHER THE BRACKET OR BAR PIN WHICH COULD RESULT IN THE LOSS OF VEHICLE CONTROL AND POSSIBLE PERSONAL INJURY OR PROPERTY DAMAGE.

12. With the shims properly adjusted and positioned, install new 1" bolts, new 1" washers and new 1" locknuts as shown in Figure 10. Recheck the axle spacing to confirm that the axle spacing from side to side is within 3/16".
13. If further adjustment is necessary, repeat step 1 through 12 in this subject. Tighten all locknuts to 450 to 600 ft. lbs. torque.

WARNING: IMPROPER TORQUE CAN RESULT IN A LOOSE OR BROKEN CONNECTION WHICH COULD RESULT IN THE LOSS OF VEHICLE CONTROL AND PERSONAL INJURY OR PROPERTY DAMAGE.

14. Verify that all beam end connections have two (2) shims included in the installation and that all 1" locknuts are torqued to 450-600 ft. lbs.

WARNING: OMISSION OF SHIMS AND/OR IMPROPER TORQUE CAN RESULT IN A LOOSE OR BROKEN CONNECTION AND COULD RESULT IN THE LOSS OF VEHICLE CONTROL AND POSSIBLE PERSONAL INJURY OR PROPERTY DAMAGE.

15. Reassemble the upper torque rods.
16. Remove the vehicle from the frame jacks. Move vehicle back and forth several times, recheck alignment to confirm adjustments.



A Boler Company

The Boler Company.
Copyright ©1993
Hendrickson Truck
Suspension Systems
All Rights Reserved.