

H TECHNICAL PUBLICATION

RS-340 Thru 520

NO: 17730-064

SUBJECT: Springing: Frame Hangers, Load Cushions
and Saddle Assembly

EFFECTIVE DATE: July 1993 REVISION: E

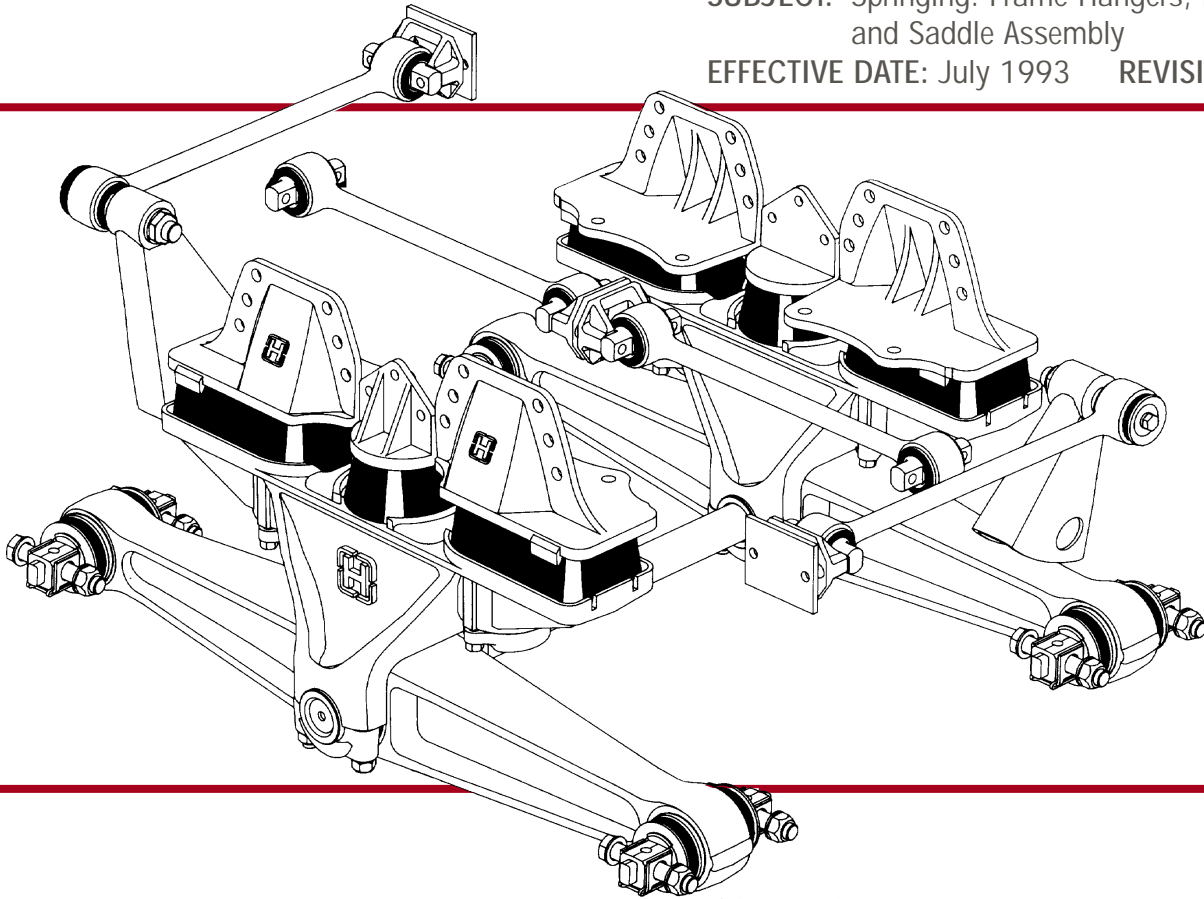

CONTENTS

Item	Subject	Page
1	Introduction	2
2	Important Safety Notice	2
3	RS Series Description	3
4	Alignment	5
5	Preventive Maintenance	5
	Frame Hangers	5
	Load Cushions	6
	Vertical Drive Bushings	6
	Saddle Cap Fasteners	6
6	Disassembly	7
	Load Cushion	
	Recommendation Chart	8
7	Reassembly	9
8	Tightening Torque Chart	12



Subject 1 INTRODUCTION

This publication is to acquaint and assist maintenance personnel in preventive maintenance and rebuild of the RS-340 through RS-520 series suspensions. The RS-340 is out of production as of January 1, 1989.

Use only genuine Hendrickson replacement parts for servicing these suspensions. Most Hendrickson parts can be identified by the Hendrickson  trademark.

DO NOT MODIFY OR REWORK PARTS.

DO NOT USE SUBSTITUTE PARTS.

USE OF A MODIFIED OR SUBSTITUTE PART IS NOT RECOMMENDED BECAUSE THE PART MAY NOT MEET HENDRICKSON'S SPECIFICATIONS, WHICH COULD RESULT IN FAILURE OF THE PART, LOSS OF VEHICLE CONTROL, AND POSSIBLE PERSONAL INJURY OR PROPERTY DAMAGE.

Note the date of this publication. Hendrickson Suspension periodically revises and updates this publication. If this copy is more than one year old, contact Hendrickson Suspension to determine if a later copy is available.

Subject 2 IMPORTANT SAFETY NOTICE

Proper service and repair is important to the safe and reliable operation of the tandem suspension. The service procedures recommended by Hendrickson and described in this technical publication are effective methods of performing maintenance.

There are various warnings that should be read carefully to minimize the risk of personal injury and to assure that proper methods are used. Improper servicing may damage the vehicle or render it unsafe in operation.

WARNING:

HENDRICKSON SUSPENSION REMINDS USERS TO ADHERE TO THE PUBLISHED CAPACITY RATINGS FOR THE SUSPENSIONS. ADD ON AXLE ATTACHMENTS AND OTHER LOAD TRANSFERRING DEVICES CAN INCREASE THE SUSPENSION LOAD ABOVE THE RATED AND APPROVED CAPACITIES WHICH COULD RESULT IN FAILURE AND LOSS OF VEHICLE CONTROL, POSSIBLY CAUSING PERSONAL INJURY OR PROPERTY DAMAGE.

ALUMINUM COMPONENTS WERE DESIGNED TO BE LIGHTWEIGHT OPTIONS WHERE WEIGHT REDUCTION IS DESIRABLE. THEIR USE SHALL BE CONFINED TO APPLICATIONS WHERE THE RATED CAPACITY OF THE SUSPENSION WILL NOT BE EXCEEDED. FAILURE TO LIMIT ALUMINUM COMPONENT APPLICATIONS TO RATED CAPACITY COULD RESULT IN CATASTROPHIC FAILURE OF THE COMPONENT AND LOSS OF VEHICLE CONTROL, POSSIBLY CAUSING PERSONAL INJURY OR PROPERTY DAMAGE.

ALUMINUM COMPONENTS SUCH AS EQUALIZING BEAMS CAN BE DAMAGED WITH PROLONGED EXPOSURE TO SALT, OR TO ACID WHICH IS SOMETIMES USED TO REMOVE CONCRETE. CONTINUED EXPOSURE COULD RESULT IN A FAILURE OF THESE PARTS AND LOSS OF VEHICLE CONTROL POSSIBLY CAUSING PERSONAL INJURY OR PROPERTY DAMAGE.

ALUMINUM COMPONENTS CAN ALSO BE DAMAGED BY CONTACT WITH HARD OBJECTS WHICH GOUGE THESE PARTS. THESE CONDITIONS COULD RESULT IN A FAILURE OF THESE PARTS WHICH MAY RESULT IN THE LOSS OF VEHICLE CONTROL AND POSSIBLE PERSONAL INJURY OR PROPERTY DAMAGE.

DO NOT MODIFY OR REWORK PARTS. DO NOT USE SUBSTITUTE PARTS. USE OF A MODIFIED OR SUBSTITUTE PART IS NOT RECOMMENDED BECAUSE THE PART MAY NOT MEET HENDRICKSON'S SPECIFICATIONS, WHICH COULD RESULT IN FAILURE OF THE PART, LOSS OF VEHICLE CONTROL, AND POSSIBLE PERSONAL INJURY OR PROPERTY DAMAGE.

DO NOT USE A CUTTING TORCH TO REMOVE ANY ATTACHING FASTENERS. DO NOT USE A CUTTING TORCH TO REMOVE THE VERTICAL DRIVE BUSHINGS FROM THE ALUMINUM SADDLES. DO NOT USE A CUTTING TORCH TO REMOVE THE EQUALIZING BEAMS FROM THE AXLES OR TO REMOVE THE BUSHINGS FROM THE BEAM CENTERS OR ENDS. ALL HENDRICKSON EQUALIZING BEAMS AND ALUMINUM SADDLES ARE HEAT TREATED FOR STRENGTH AND SERVICE LIFE. THE USE OF HEAT ON SUSPENSION COMPONENTS WILL ADVERSELY AFFECT THE STRENGTH OF THESE PARTS. A COMPONENT DAMAGED IN THIS MANNER MAY RESULT IN THE LOSS OF VEHICLE CONTROL AND POSSIBLE PERSONAL INJURY OR PROPERTY DAMAGE.



Subject 2 (Continued)
IMPORTANT SAFETY NOTICE

A MECHANIC USING A SERVICE PROCEDURE OR TOOL WHICH HAS NOT BEEN RECOMMENDED BY HENDRICKSON MUST FIRST SATISFY HIMSELF THAT NEITHER HIS SAFETY NOR THE VEHICLE'S SAFETY WILL BE JEOPARDIZED BY THE METHOD OR TOOL SELECTED.

THE USE OF EXCHANGE EQUALIZING BEAMS IS STRICTLY DISCOURAGED UNLESS THE BEAMS WERE ORIGINALLY FROM THE SAME CUSTOMER WHERE THE HISTORY OF THEIR SERVICE IS SPECIFICALLY KNOWN. USING EXCHANGE BEAMS OF UNKNOWN ORIGIN, WHERE TIME IN SERVICE OR APPLICATION AND LOADINGS ARE NOT KNOWN, CAN LEAD TO FAILURE, RESULTING IN THE LOSS OF VEHICLE CONTROL AND POSSIBLE PERSONAL INJURY OR PROPERTY DAMAGE.

Subject 3
DESCRIPTION

The RS Series of suspensions are available in two basic models. The "Maintenance Free" shown in Figure 1A is the standard offering and includes nodular iron frame hangers, rubber beam bushings and transverse rods and is specifically targeted to the refuse and logging industries.

The "High Articulator" shown in Figure 1B includes bronze center bushings and steel frame hangers and is offered on selected applications which require the maximum articulation and wheel travel to enhance mobility to support off-highway requirements.

Both suspensions are available in 38,000# to 52,000# capacity.

The RS series suspensions as shown in Figures 1A and 1B use four rubber load cushions in place of leaf springs to cushion road shocks. These cushions are available in several durometer hardness readings to suit specific applications. Each cushion has an inner cross bar that helps support the load when the vehicle is loaded. An empty vehicle is supported only by the outer edges of the cushions as shown in Figure 2.

Figure 1A RS/Maintenance Free

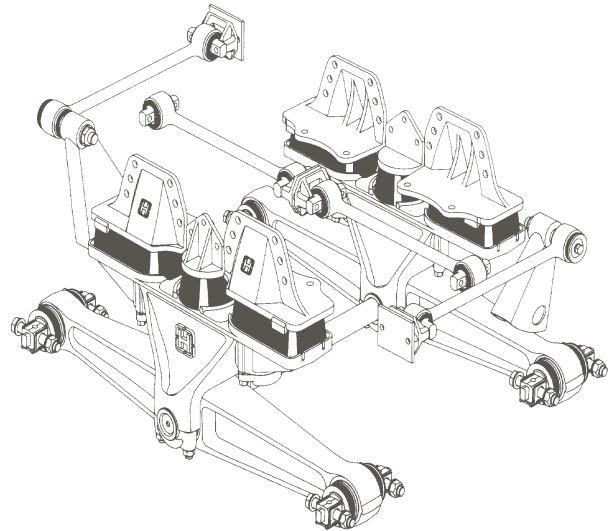
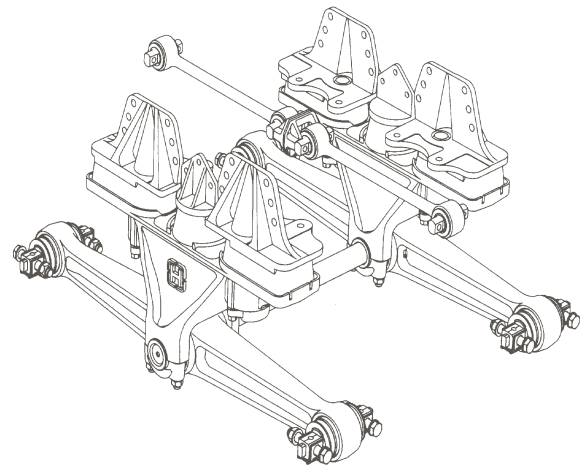

Figure 1B RS/High Articulator





Subject 3 (Continued)
DESCRIPTION

The frame hangers above each cushion are attached to the frame. These hangers have vertical drive pins that extend down through the load cushions and are secured to rubber vertical drive bushings in lightweight aluminum saddles. All driving, braking and cornering forces are transmitted through these pins.

The vertical drive bushings allow the saddles to move up and down as the load cushions deflect, but maintain lateral and fore and aft alignment of the saddles as shown in Figure 2.

A heavy duty kit, as shown in Figure 3, consisting of an additional round center cushion and related brackets on each side of the chassis, is available as an option for the RS-400 series, and is standard on the RS-460, RS-480 and RS-520 series. This option increases stability in oil field, refuse, transit mix and logging operations.

A rebound control stop kit, as shown in Figure 4, consisting of special stop nuts and elastomer bumpers, is available to increase stability control in operations where the vehicle is subjected to high center of gravity or offset loading. This option restricts the upward pull of the frame hanger pins and washers into the rubber vertical drive bushings. These are standard on the RS-520 and optional for the RS-400 through RS-480 series.

This combination of components provides light weight, stability, and low maintenance with no lubrication requirements.

Figure 2

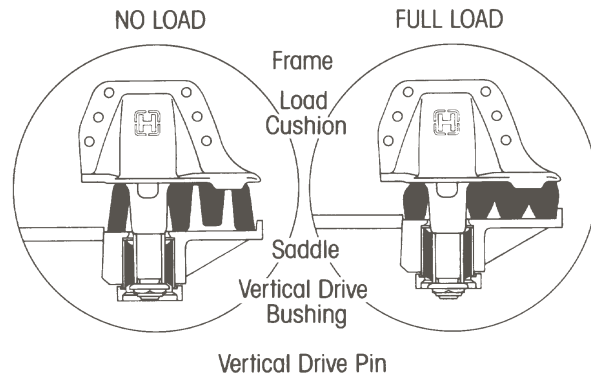

Figure 3

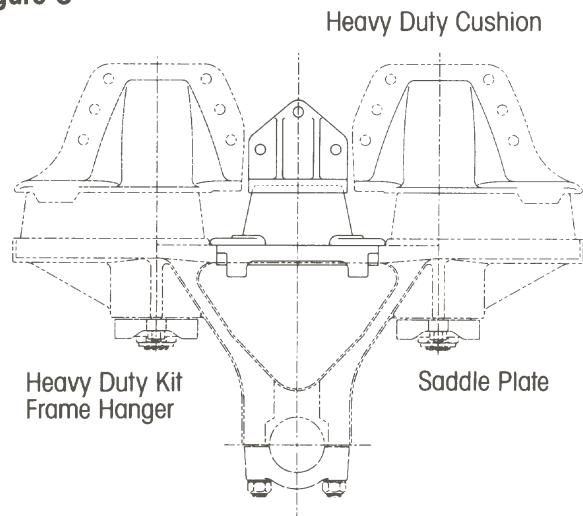
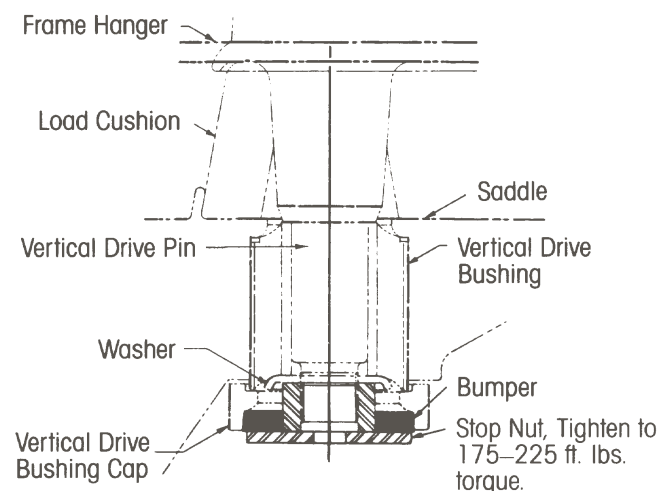

Figure 4





Subject 4
ALIGNMENT

The points controlling alignment are:

The location of the frame hangers on the frame as installed by the vehicle manufacturer.

The location of the beam hangers on the axles as installed by the axle manufacturer or the truck manufacturer.

If your vehicle has the bar pin connector, refer to 17730-190.

Subject 5
PREVENTIVE MAINTENANCE

Frame Hangers. Before a new vehicle is placed in service, and at least once a year thereafter, check the frame hanger to frame attaching fasteners for proper tightening torque and retighten if necessary. These fasteners are supplied and installed by the vehicle manufacturer. Follow the tightening torque instructions in the service manual provided by the vehicle manufacturer; or refer to the tightening torque specification chart included in this technical publication.

FASTENERS THAT DO NOT PROVIDE A TIGHTLY CLAMPED JOINT BETWEEN THE FRAME AND THE HANGERS CAN CAUSE PREMATURE FRACTURE OF THE FRAME HANGERS, SEPARATION OF COMPONENTS, LOSS OF VEHICLE CONTROL AND POSSIBLE PERSONAL INJURY OR PROPERTY DAMAGE.

WARNING: Older vehicles, high mileage vehicles, and all vehicles in severe service such as transit mix and refuse operations, must be inspected at least once a year as follows:

Visually inspect each frame hanger for any evidence of cracks in the vertical mounting flange as shown in Figure 5. Replace any hanger that may have cracks.

Visually inspect each frame hanger for evidence of cracks in the horizontal mounting flange adjacent to the vertical drive pin area as shown in Figure 6. Also inspect each frame hanger for severe rust on the horizontal mounting flange as shown in Figure 7. These two inspection areas will require removal of the hanger from the frame for thorough inspection. Replace any hanger that may have cracks or severe rust. **IMPORTANT NOTE:** 'B' style hangers are not suitable for welding.

When hanger replacement is necessary, refer to the Hendrickson Frame Hanger Selection Guide (Publication #45745-037). For maximum life, component selection must conform to the recommendations regarding the RS/Maintenance Free or the RS/High Articulator.

Vehicles Built
1990 and Prior

Vehicles Built
in 1990 to Present

Figure 5

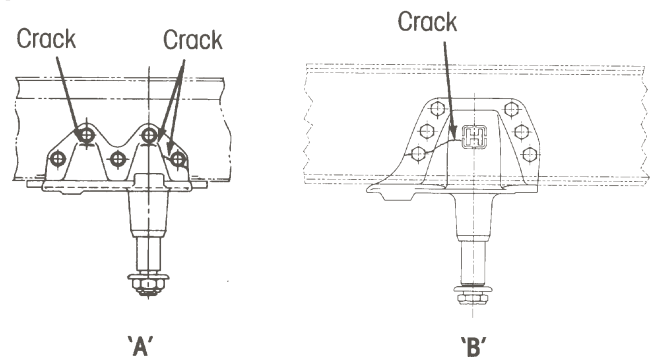

Figure 6

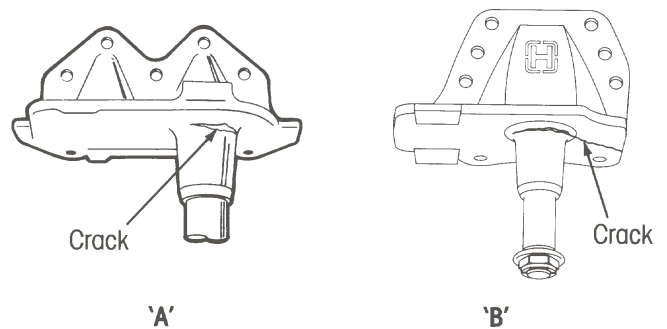
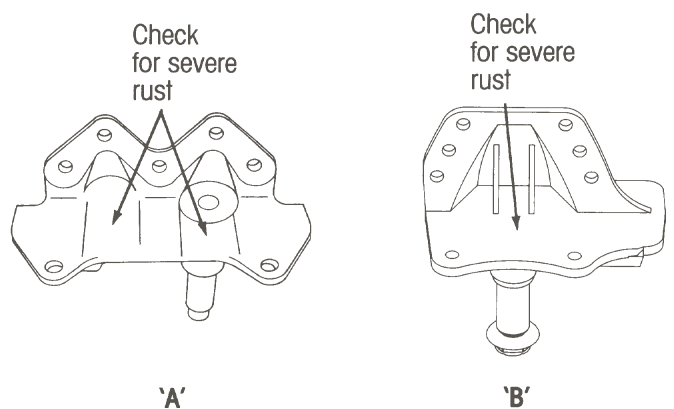

Figure 7



Subject 5 (Continued)
PREVENTIVE MAINTENANCE

Complete fracture of the horizontal flange can be detected by lifting the chassis by the frame and observing this area for separation of the vertical drive pin from the horizontal flange of the hanger. If this condition is observed, do not operate the vehicle. Replace the frame hanger immediately.

SAFETY NOTE: USE CAUTION WHEN APPLYING THESE TECHNIQUES SO THAT PERSONAL SAFETY AND VEHICLE SAFETY ARE NOT JEOPARDIZED.

WARNING: DO NOT OPERATE A VEHICLE WITH CRACKED, BROKEN, OR SEVERELY RUSTED FRAME HANGERS. OPERATING A VEHICLE WITH A CRACKED, BROKEN, OR SEVERELY RUSTED FRAME HANGER CAN LEAD TO SEPARATION OF COMPONENTS, LOSS OF VEHICLE CONTROL, AND POSSIBLE PROPERTY DAMAGE AND PERSONAL INJURY.

Load Cushions. Inspect cushions for cuts and swelling at least once a year. Cushions cut by the retaining lips of the saddles or frame hangers indicate the cushions may not be the correct hardness or configuration for the operation of the vehicle, or may require rebound control with the rebound control stop kit. Transit mix and dump operations may cause a build up of dirt and material under the cushions resulting in the cushions escaping from the retainer lips on the saddles and twisting out of position.

Vertical Drive Bushings. Inspect the lower side of these bushings for evidence of torn or shredded rubber at least once a year. Be sure the concave washers are installed with the lips pointing downward. The vertical bushing retainer caps can be removed to facilitate inspection.

Saddle Cap fasteners. The locknuts should be tightened as shown in Figure 8 to prevent wear of the beam center bushings into the legs of the saddles.

Figure 8

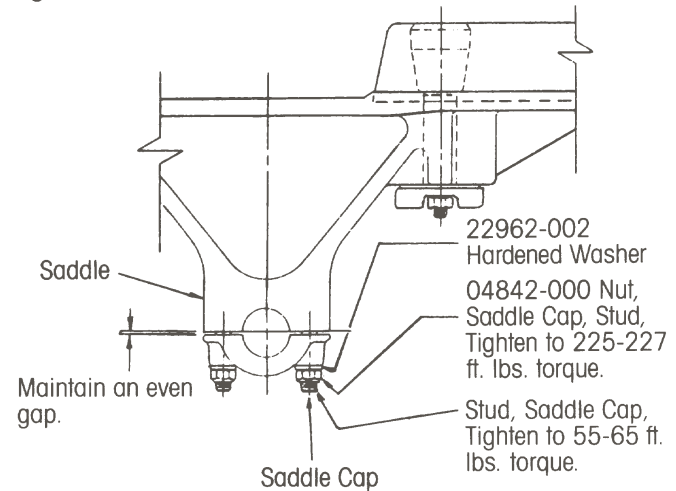



Subject 6 DISASSEMBLY

Experience in servicing the RS series suspensions indicates that when a major overhaul is required, the complete tandem unit should be removed from the frame. However, the torque rods, load cushions, equalizing beams and other components may be removed separately, as necessary. (See Technical Publication 17730-190.)

Heavy duty load cushions. These cushions may be replaced without disassembly of the suspension by raising the frame and allowing the weight of the axles to open the area between the brackets. The cushions can then be forced out and replaced.

Saddle assemblies and load cushions. With the equalizing beams and axles rolled out from under the frame, support the saddle assembly on a floor jack as shown in Figure 9.

Remove the vertical drive pin locknuts, or rebound control stops if so equipped, and concave washers as shown in Figure 10. Remove the saddle and load cushions from the vertical drive pins. Remove the saddle and load cushions from the opposite side of the chassis in the same manner.

Figure 9

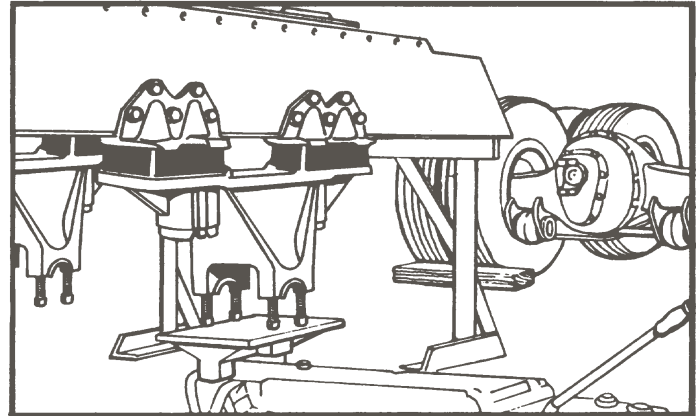
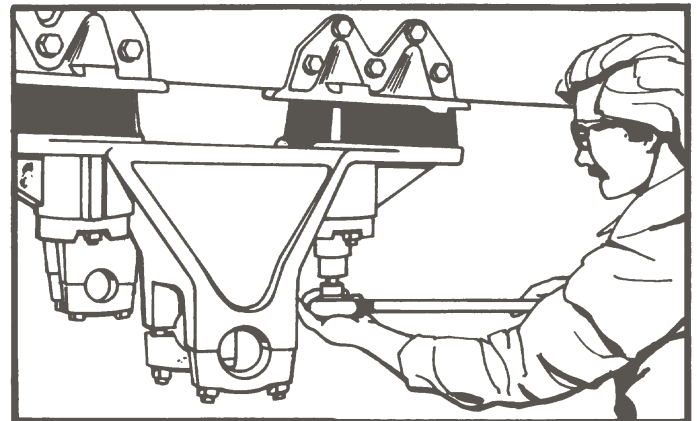

Figure 10





Subject 6 (Continued)
DISASSEMBLY

Frame Hangers. Remove the frame hangers from the frame.

Saddles. Remove the vertical drive bushing retainer locknuts and the retainers. Press out the vertical drive bushings from the top side. If the outer metals of the bushings are frozen in the saddle bores, press the inner metals and rubber inserts out of the bushings, and work the outer metals out of the saddle bores. Do not cut any remaining outer metals with a torch or use heat to remove the outer metals. Clean the saddle bores with solvent and remove any nicks with emery cloth. Saddles manufactured after July 1990 have a steel ring seated against the shoulder of the vertical drive bushing bore which must be left in place.

Load Cushions. Load cushions that are cut or damaged should be replaced. The free height of new cushions is 3.94". Used cushions that measure less than 3.68" in height when measured by themselves on a flat surface have taken a permanent set and should also be replaced. The chart below lists the correct load cushion part numbers for specific vehicle applications.

OPERATION	SUSPENSION	PART NO.
Highway	RS-340 & 400	Front 48973-000 Rear 48972-000
On & Off Highway	RS-400 (includes transit mix up to 8 cu. yd. capacity)	48973-000
	RS-460 thru 520	26953-000
Off Highway	RS-460 thru 520	26953-000
Heavy Duty Cushion	Standard for RS-460 thru 520 Optional for RS-400	24209-000

Load cushions are made from different natural rubber compounds to achieve different load carrying capabilities. Our manufacturing specifications control the amount of cushion deflection at rated load. The durometer hardness readings shown below are for identification only and the actual durometer hardness may vary.

The cushion part number is molded in a circular medallion on the flat end of the cushion.

PART NO.	DUROMETER	COLOR CODE
48973-000	60	Blue
48972-000	40	White
24209-000*	70	None
26953-000	70	Yellow

*Heavy Duty Kit Load Cushion



Subject 7
REASSEMBLY

Saddles. With the vertical drive bushing bores cleaned, apply a rust preventive to these bores and to the outside diameter of the vertical drive bushings and assemble the bushings into the bores. These bushings are not a press fit and they should slide into the bores of the saddles. Saddles manufactured after July 1990 have a steel ring seated against the shoulder of the vertical drive bushing bore which must be left in place. Reassemble the vertical drive bushing caps and locknuts. Tighten the locknuts evenly as shown in Figure 11.

Figure 11

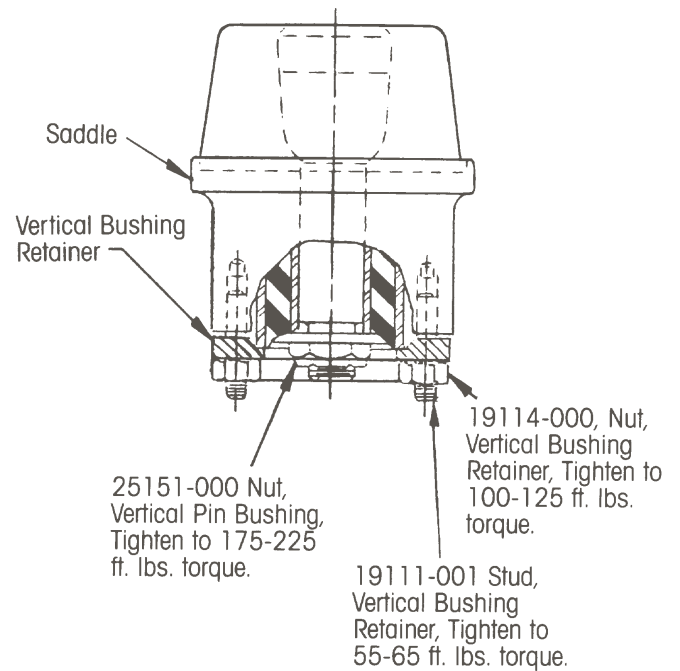



Subject 7 (Continued)
REASSEMBLY

Frame Hangers. Install new, or removed and inspected frame hangers on the frame. The vehicle manufacturer furnishes the fasteners that attach these parts to the frame. Follow their recommended tightening torque values for these fasteners. Hendrickson recommends the use of grade 8 bolts, grade C locknuts, and flat, plated, hardened washers under the bolt heads and locknuts as shown in Figure 12.

These hangers are of a clamp type design with either five or six bolts in the vertical mounting flange and two bolts in the horizontal mounting flange. The five bolt frame hangers will not be used on any new vehicle builds after the end of 1990.

It is important that a full length spacer be installed between the horizontal flange holes and the underside of the frame reinforcing liner. The thickness of the spacer must be equal to the gap between the hanger flange and the frame liner. This is usually the same as the thickness of the main frame rail. Correctly installed spacers prevent bending of the hangers or frame members when the fasteners are tightened, and ensure a structurally sound installation.

It is also important that the hanger fit tight and flush against the bottom of the main frame rail when the attaching fasteners are tightened.

Figure 12

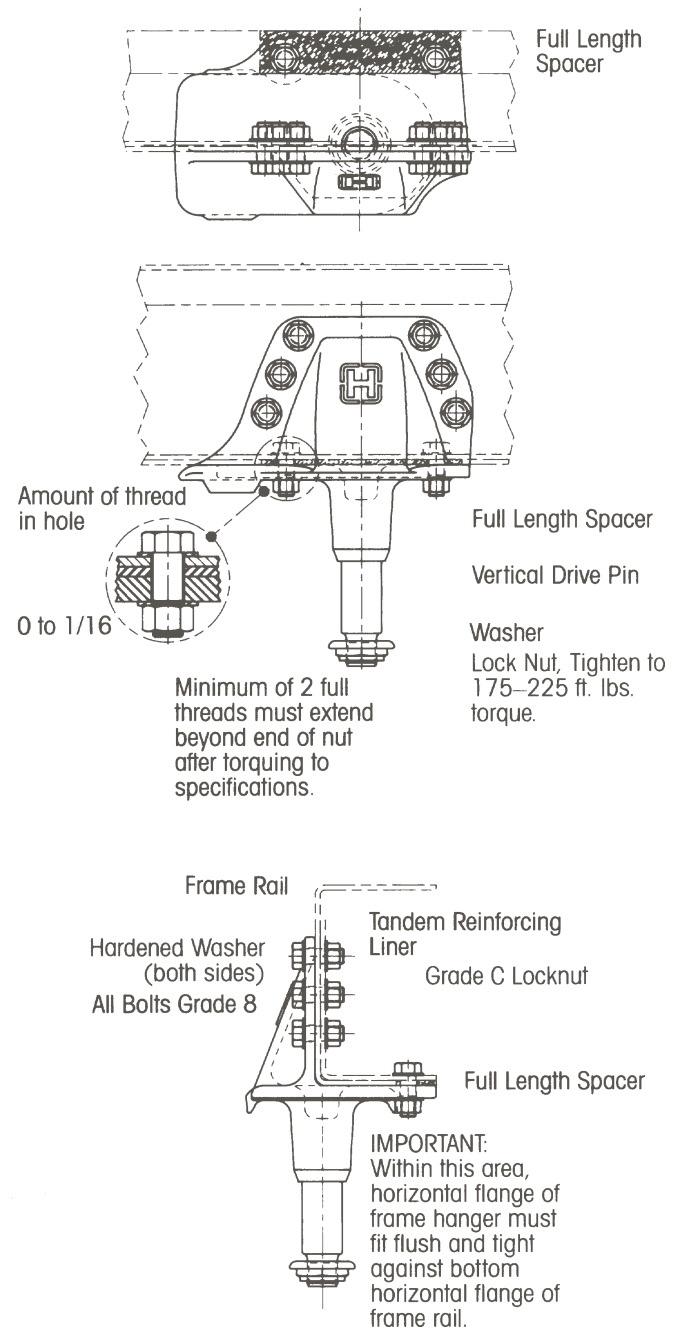



Subject 7 (Continued)
REASSEMBLY

Saddle Assemblies and Cushions. Coat the frame hanger vertical drive pins and the vertical drive bushing inside diameters with rust preventive. Position the load cushions on the saddles and raise the saddles, guiding the vertical drive bushings over the frame hanger pins.

Assemble the drive pin washers over the threaded ends of the drive pins with the concave washer lips pointing downward. If these washers are installed upside down, the washer lips will cut into the rubber of the vertical drive bushings and restrict the normal movement of the bushings which can affect ride characteristics. Properly installed washers allow the correct upward motion of the vertical drive bushings with the rounded side of the concave washer snubbing up against the rubber.

Assemble the vertical drive pin locknuts and tighten as shown in Figure 11. When the locknuts are correctly tightened, the ends of the vertical drive bushing inner metals are clamped securely between the shoulders of the frame hangers and the concave washers. All motion is accommodated by rubber deflection and there is no movement between mating metal surfaces.

If the rebound control stop kit is to be installed, the standard vertical drive pin locknuts will not be used. Assemble the special stop nuts and bumpers with the existing concave washers in their original positions as shown in Figure 13.

Equalizing beams. Roll the axles with equalizing beams attached under the vehicle as outlined in Technical Publication 17730-190. With the saddle caps removed, lower the chassis so that the saddles contact the equalizing beam center bushings.

With the weight of the chassis on the beam center bushings, assemble the saddle caps, washers, and locknuts. Tighten the locknuts evenly to prevent distortion of the saddle caps and studs as shown in Figure 14. Maintain an even gap between the saddle caps and the base of the saddle legs to avoid possible distortion of the caps and bending of studs which may result from loose caps.

NOTE: See Technical Publication 17730-190 for additional information pertaining to equalizing beams, cross tubes, and torque rods.

Figure 13

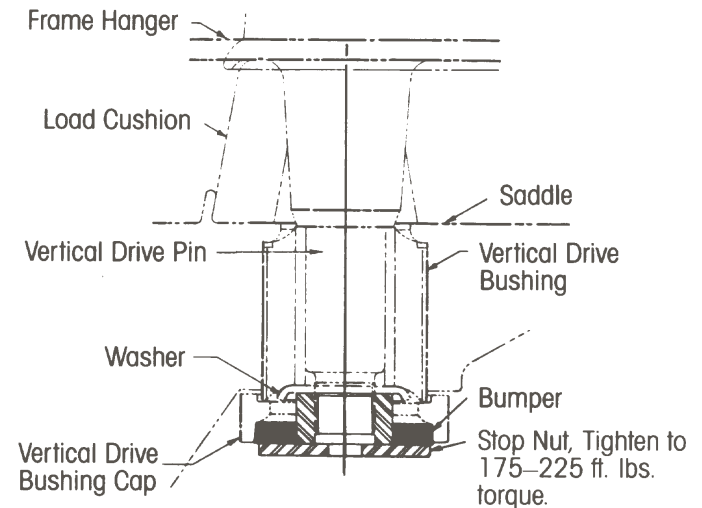
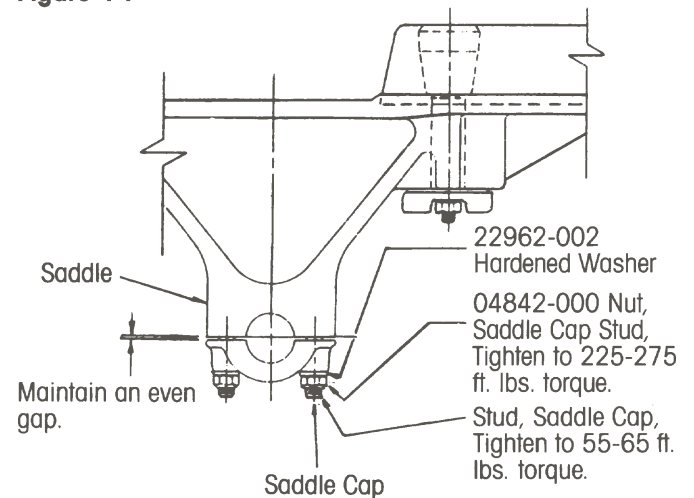

Figure 14





Subject 8
TIGHTENING TORQUE SPECIFICATION CHART

DESCRIPTION	HENDRICKSON PART NO.	THREAD/ GRADE	RECOMMENDED TORQUE (FT./LBS.)
Vertical Drive Pin Locknut	25151-000	1 1/2"-12 UNF-2B Grade 5	175-225
Rebound Control Stopnut	30251-000	1 1/2"-12 UNF-2B	175-225
Retainer Stud Locknut	19114-000	5/8-18 UNF-2B Grade A	100-125
Vertical Drive Bushing Retainer Stud	19111-001	5/8-11 UNC-2A Grade 5	55-65
Saddle Cap Stud Locknut	04842-000	7/8-14 UNF-2B Grade B	225-275
Saddle Cap Stud (340)	09029-000	7/8- 9 UNC-2A Grade 5	55-65 50-70
Saddle Cap Stud (380-520)	09030-000	7/8-9 UNC-2A Grade 5	55-65

All threads must be clean and lubricated with SAE 20 oil before assembly to obtain the correct relationship of torque and fastener tension.

To obtain maximum service life from the suspension system, mounting bolts and nuts should be checked at least once a year and tightened to specified torque.

