



TECHNICAL PROCEDURE

RT™/RTE™ Top Pad Bolts

SUBJECT: Top Pad Bolt Length
Selection Guide

LIT NO: 17730-189

DATE: June 2008

REVISION: C

INTRODUCTION

This publication is intended to assist maintenance personnel with the proper selection and installation of Hendrickson approved Grade 8 top pad bolts for Hendrickson RT™/RTE™ Series suspensions. Hendrickson offers such bolts in various dimension "A" lengths in ¼" increments from 7¾" to and including 14 inches (see Figure 1) depending upon the Hendrickson spring assembly used in the particular RT/RTE suspension. Refer to the top pad bolt selection matrix below for length selection.

For complete RT/RTE Series service and safety instructions regarding component replacement, see Technical Publication 17730-070.

CAUTION

INCORRECT TOP PAD BOLT LENGTHS CAN RESULT IN (1) FAILURE TO SUSTAIN PROPER CLAMP FORCE, (2) REDUCED AXLE/BEAM ARTICULATION, (3) INAPPROPRIATE CONTACT BETWEEN THE TOP PAD BOLT AND THE BEAM OR FRAME RAIL, ALL OF WHICH CAN CAUSE PREMATURE COMPONENT DAMAGE, PERSONAL INJURY, LOSS OF VEHICLE CONTROL, OR PROPERTY DAMAGE.

FIGURE 1

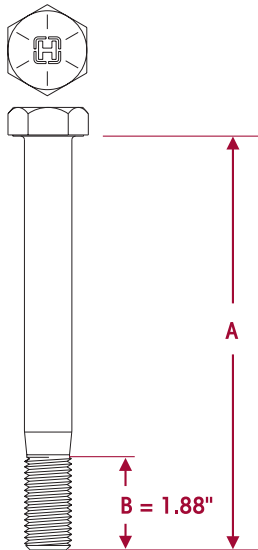

TOP PAD BOLT SELECTION

The proper bolt length (as shown in Figure 1) can be determined by using the following guidelines:

- Dimension "A" – measure the removed bolt
- Ensure Dimension "A" is 3¼" plus the thickness of the spring assembly
- Dimension "B" is 1.88"

PART NUMBER	DIM. A	PART NUMBER	DIM. A
30550-016	7.75"	30550-010	11.00"
30550-017	8.00"	30550-011	11.25"
30550-018	8.25"	30550-012	11.50"
30550-019	8.50"	30550-013	11.75"
30550-001	8.75"	30550-014	12.00"
30550-002	9.00"	30550-015	12.25"
30550-003	9.25"	30550-020	12.50"
30550-004	9.50"	30550-021	12.75"
30550-005	9.75"	30550-022	13.00"
30550-006	10.00"	30550-023	13.25"
30550-007	10.25"	30550-024	13.50"
30550-008	10.50"	30550-025	13.75"
30550-009	10.75"	30550-026	14.00"

AFTER tightening to  275-325 foot pounds torque in the proper sequence, verify that a **MINIMUM** of 3 full threads to a **MAXIMUM** of 5 full threads extend beyond the end of the locknut, see Figure 2. These guidelines are necessary to help ensure:

- Full thread engagement in the locknuts.
- Proper clearance between the top pad bolt and the equalizing beams, or the frame and the top bolt in inverse bolt installations.

FIGURE 2

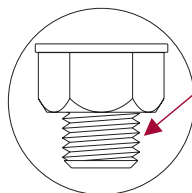

3 Minimum to 5 Maximum full threads showing after tightening to torque specifications. Tightening torque 275-325 ft. lbs.

NOTE Using the correct length top pad bolt is important to help ensure the RT/RTE suspension system and components function to their highest efficiency.



TOP PAD BOLT INSTALLATION

See Hendrickson publication 17730-070 and any applicable vehicle manufacturer referenced materials for additional safety instructions regarding replacement of components.

1. Assemble the top pad between the saddle chair back ears and on top of the main leaf of the spring assembly. The main leaf has either a flat washer or a pilot cup forged upward at the center bolt that pilots into a cavity in the top pad.

NOTE This feature provides the correct alignment of the spring assembly in the saddle.

2. Assemble the four top pad bolts (lubricate all threads with SAE-30 oil before assembly) with washers and locknuts through the top pad and saddle, see Figure 3.

NOTE Some RT/RTE suspension configurations require inverted top pad bolt installation. See vehicle manufacturer for specific top pad fastener configuration.

3. Snug the top pad bolt locknuts enough to hold the assembly in place, approximately 100 foot pounds torque.
4. Assemble the top pad set screws for the appropriate RT/RTE suspension capacity as follows:

• **RT/RTE 340-523**

Assemble the top pad set screw fasteners, (lockwasher, locknut, and square head bolt), see Figure 4. Tighten the square head bolt to 100 to 150 foot pounds torque, then tighten the set screw locknut to 100-150 foot pounds torque, see Figure 4.

• **RT 650**

Assemble the top pad internal hex head set screw and tighten to 120-200 foot pounds torque, see Figure 4.

5. Evenly tighten the top pad bolt locknuts in 100 foot pound increments in the proper sequence as shown in Figure 4, until the final tightening torque value of 275-325 foot pounds is achieved.

NOTE Top pad bolt locknuts must be re-tightened after the first 500 miles of service, and at regular preventive maintenance intervals, not to exceed one year or 50,000 miles, whichever comes first. DO NOT exceed specified value of 275-325 foot pounds torque on RT/RTE top pad fasteners.

Refer any questions regarding this publication to Hendrickson Tech Services at 630.910.2800 or email: techservices@hendrickson-intl.com. To obtain more information on Hendrickson products go to www.hendrickson-intl.com.

FIGURE 3

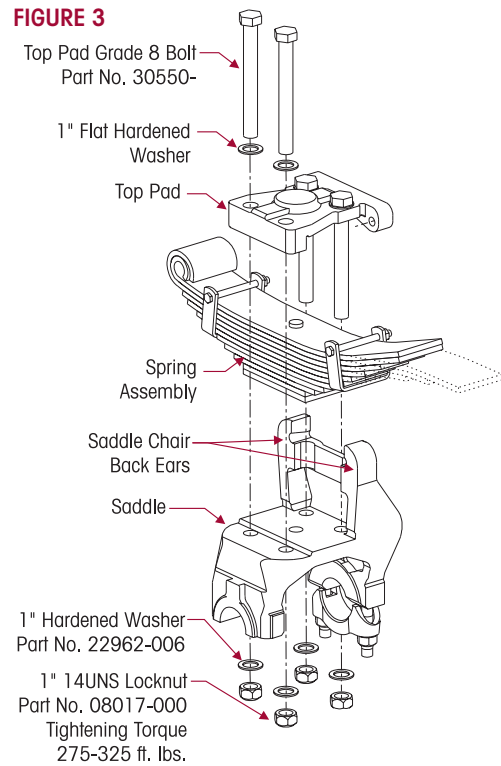
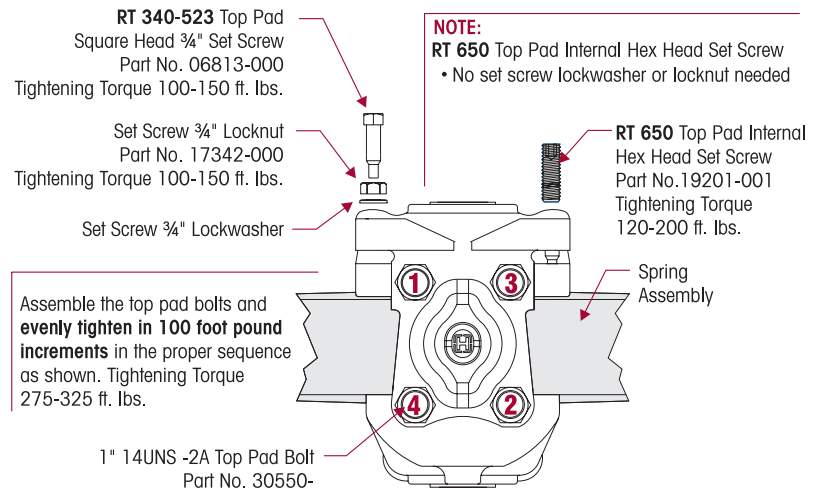

FIGURE 4



Assemble the top pad bolts and evenly tighten in 100 foot pound increments in the proper sequence as shown. Tightening Torque 275-325 ft. lbs.

1" 14UNS -2A Top Pad Bolt Part No. 30550-

www.hendrickson-intl.com



Truck Suspension Systems
800 South Frontage Road
Woodridge, IL 60517-4904 USA

630.910.2800
Fax 630.910.2899